

JOLLY ROGER

A construction project for a delightful small boat for young men of 8 to 80

By WILLIAM D. JACKSON N.A.

Craft Print Project No. 96



Even casting is possible from this boat, due to ample proportions.

JOLLY ROGER—shades of Captain Kidd and Morgan. Here is a small boat for big or little adventurers easily built of flat bottom design for those small tars who thirst for high adventure on a pond where the sunfish lurk. Despite its small size the Jolly Roger also makes an excellent yacht dinghy for father.

Construction is conventional, but easy methods to facilitate construction are new and will be explained later. To begin the construction of this paragon of small craft, accumulate the materials for various parts and saw the form and mould frames from any rough lumber, as these are later removed. Mount the form upon legs similar to a saw horse and notch it out to receive moulds and also notch out moulds for keel, chines, risers, and clamps.

Mount mould frames upon form, securing rigidly, and square. The transom and frame are now fabricated, notching out transom frame for all members. Saw the stem to shape and trim lower end to fit keel at that point. Secure transom to aft end of form and stem to fore end, fastening temporarily. Secure keel to transom frame; notch with two 1 3/4" No. 10 F.H. screws, and fasten keel at forward end to stem with one 1 3/4" No. 10 F.H. screw. The chines are now cut to fit transom frame notch, fastening with one 1 3/4" No. 10 F.H. screw to each joint, bent around moulds, ends cut to fit and fastened

LIST OF MATERIALS

Part	Pieces	Finished Sizes	
Keel (inner)	1 Pc.	3/4" x 3 1/2" x 8'	
Keel (outer)	1 Pc.	3/4" x 1" x 8'	
Chines	2 Pcs.	3/4" x 1 1/2" x 9'	Oak, Ash, or any hardwood.
Seat Risers	2 Pcs.	3/4" x 1 1/4" x 9'	
Clamps	2 Pcs.	1/2" x 1 1/4" x 9'	
Mouldings	2 Pcs.	3/4" x 1 1/8" x 9'	
Transom Frame	1 Pc.	3/4" x 2" x 5'	
Breast Hook and Stern Knees	1 Pc.	3/4" x 10" x 24"	
Stem	1 Pc.	2" x 3" x 24"	
Motor Board (transom)	1 Pc.	3/4" x 6" x 18"	
Outer Stem	1 Pc.	1 3/4" x 8" x 20"	Cedar, cypress, fir, white or yellow pine.
Seats	1 Pc.	3/4" x 12" x 8'	
Transom & Skig	1 Pc.	3/4" x 8" x 6'	
Bottom Planking	6 Pcs.	1/2" x 3 3/4" x 12'	
Side Planking (Also Oars)	1 Pc.	Weldwood Ply-wood—1/4" x 30" x 9'	

FASTENINGS

- 1 Pound Galvanized Shingle Nails 1 1/4-in.
- 6 Dozen 1 1/4" No. 8 F.H. Screws.
- 2 Dozen 1 3/4" No. 10 F.H. Screws.
- 4—3" No. 12 F.H. Screws.
- 1 Pint Cascophen Glue.
- 1 Gallon Ferdinand's Canvas Cement (if needed).

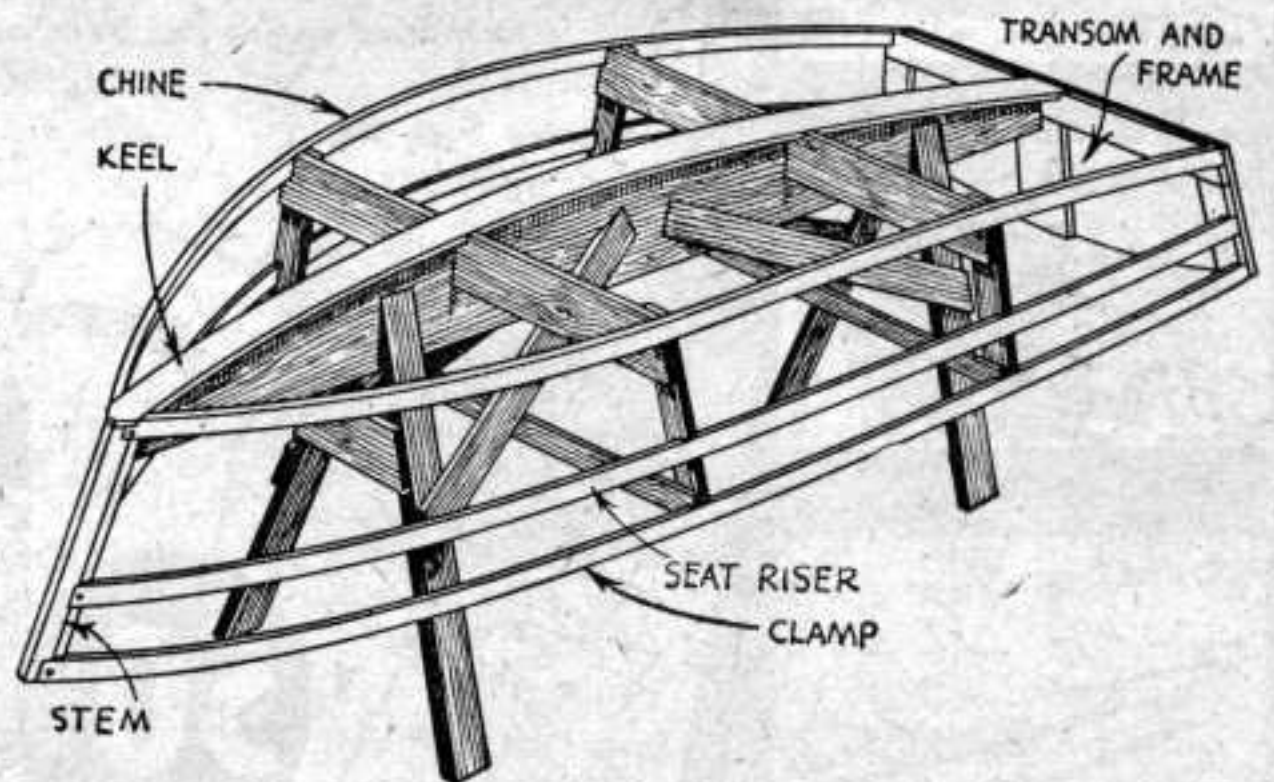

similarly to keel and stem joint. To prevent chines riding up or down on moulds, it may be necessary to fasten temporarily.

The seat risers and sheer clamps are next attached similarly, fastening with one 1 3/4" No. 10 F.H. screw to each joint, notching clamps flush with stem and notching risers only part way into

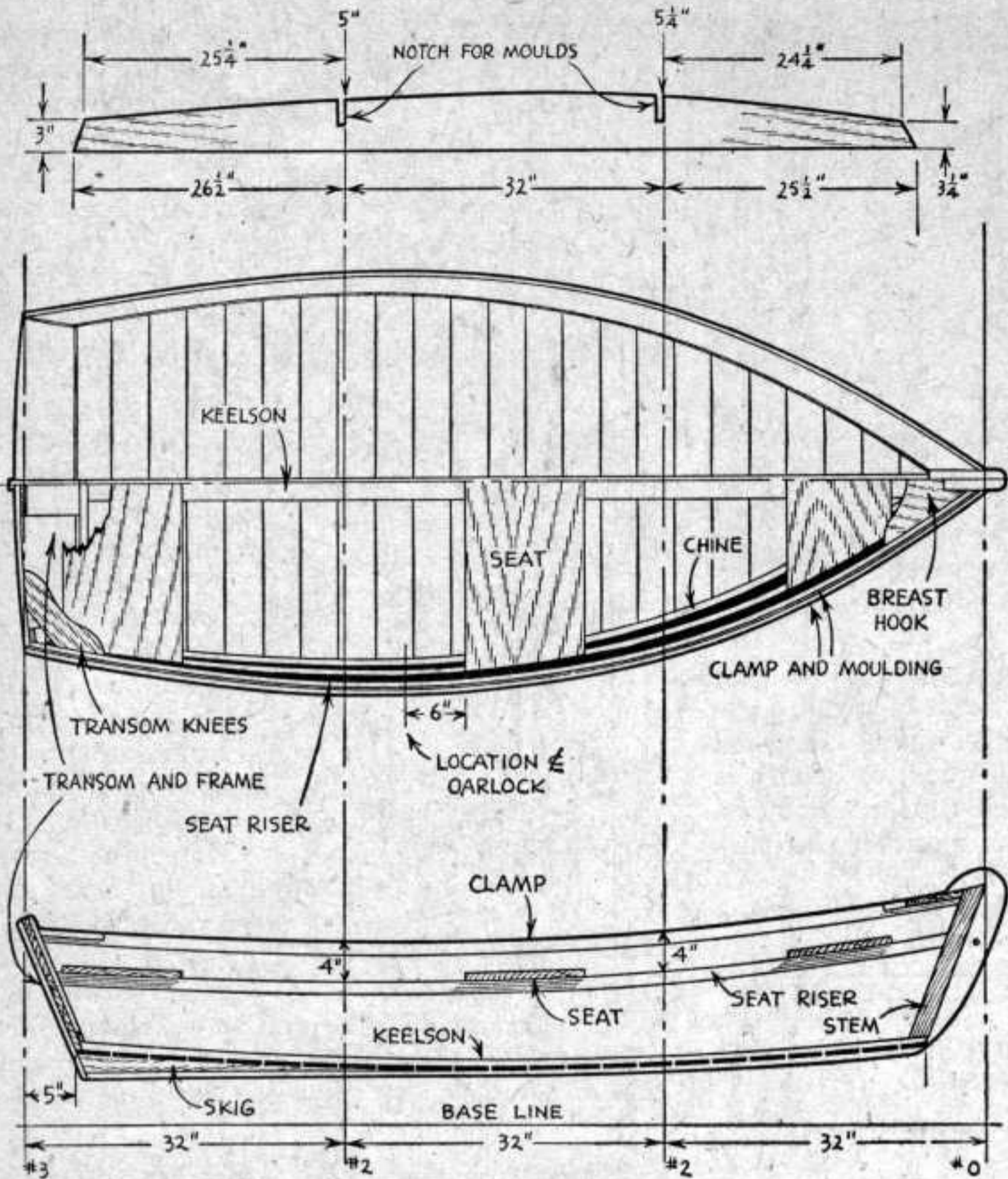

stem, to prevent weakening at this point. Trim and fair the frame work, so planking to be applied lies evenly at all points. Now any of a variety of planking methods are available—all fastened similarly. The original hull was planked cross-wise on the bottom with 1/2"x3 3/4" planks, while the sides were covered with plywood, but whether entirely planked with plywood or planking, coat adjoining surfaces with Cascophen glue, prepared according to directions, and fasten planking to members with galvanized shingle nails (1 1/4") later clinching nails on inside. For a permanently waterproof job the finished hull should be covered with cloth cemented in place with Ferdinand's canvas cement; however, if entirely plywood planked with waterproof plywood, this is not necessary.

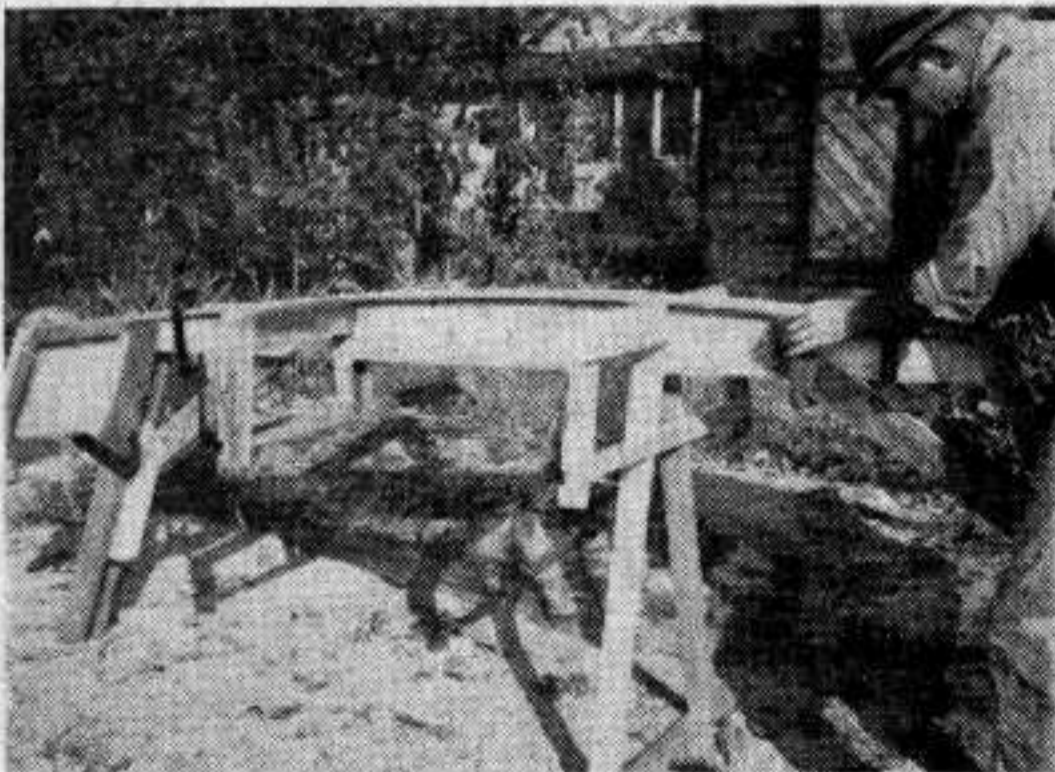

Mould frames, form set up. Transom, keel, stem attached.

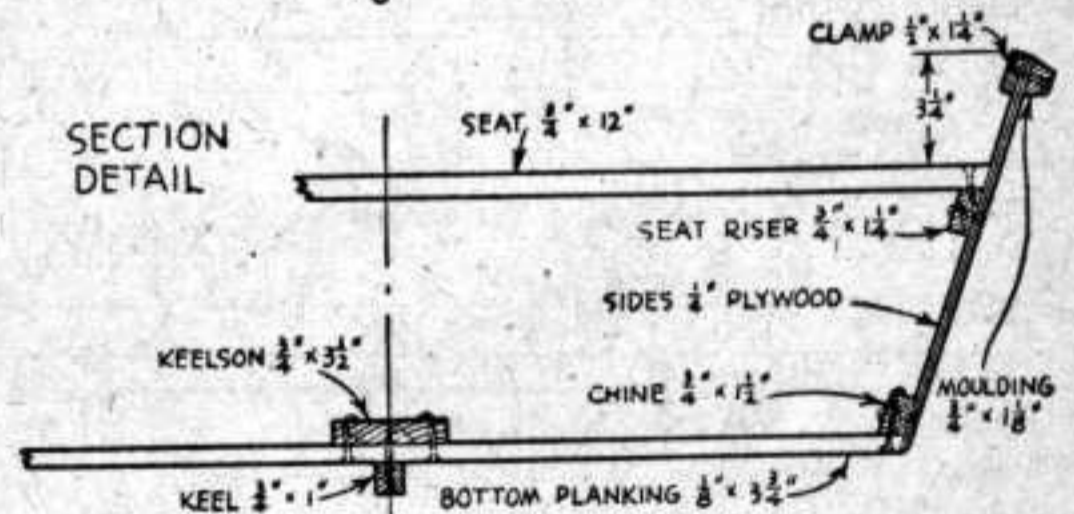

With the planking method selected, start with the bottom, coat adjoining surfaces with Cascophen glue, lay planking in position and fasten with galvanized shingle nails. Trim edges of planking and cover sides with plywood, cemented and nailed to risers, chines, and clamps, also transom and stem. Trim edges of planking evenly and insert seats at designated locations. Now remove moulds and form, as the seats maintain the shape without the aid of moulds, and when the glue sets the hull is a rigid unit.

Cut to shape and fasten transom knees and breast hook forward with 1 3/4" No. 10 F.H. screws. The shaped outer stem piece is now cut to fit and, to cover exposed edges of planking at stem, fastened in place with four 3" No. 12 F.H. screws, counterboring where necessary and finishing by trimming all edges evenly.

Fasten sheer mouldings to sides with 1 1/4" No.

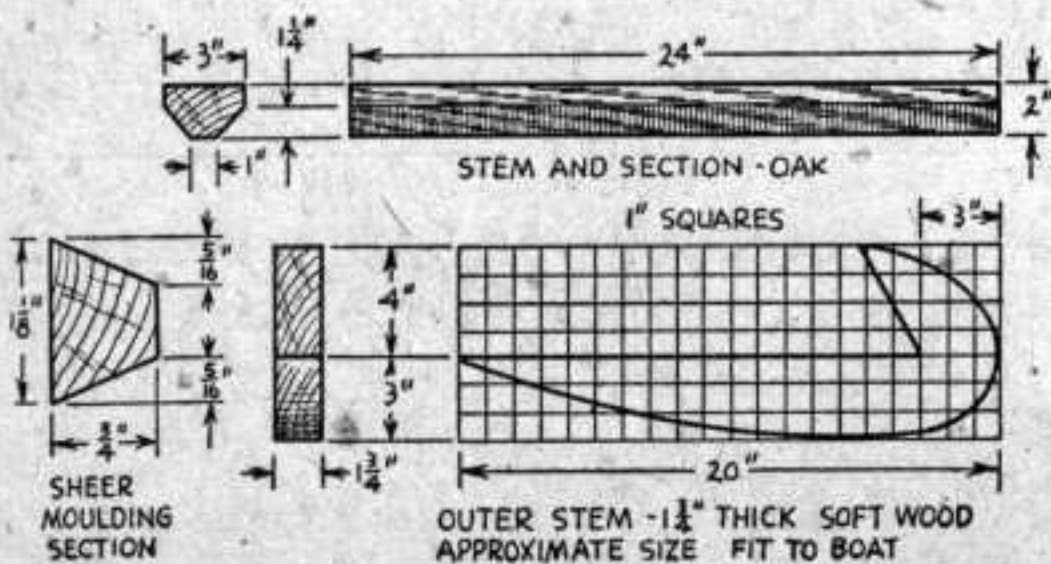

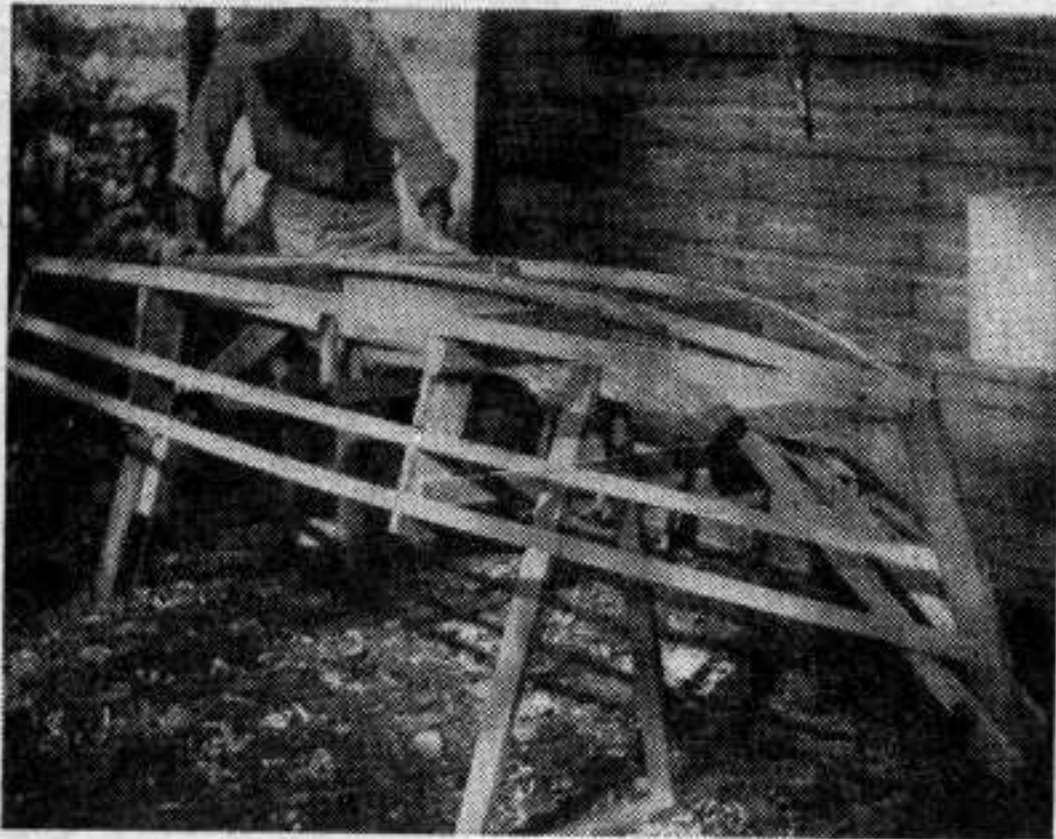

Framework completed, ready for planking.

8 F.H. screws spaced about 10" apart. Now sand and smooth hull and apply a coat of equal parts linseed oil and turpentine inside and out, and for a really permanently leakproof job, especially if the hull is planked cover with muslin cemented in place with Ferdinand's canvas cement, the sur-

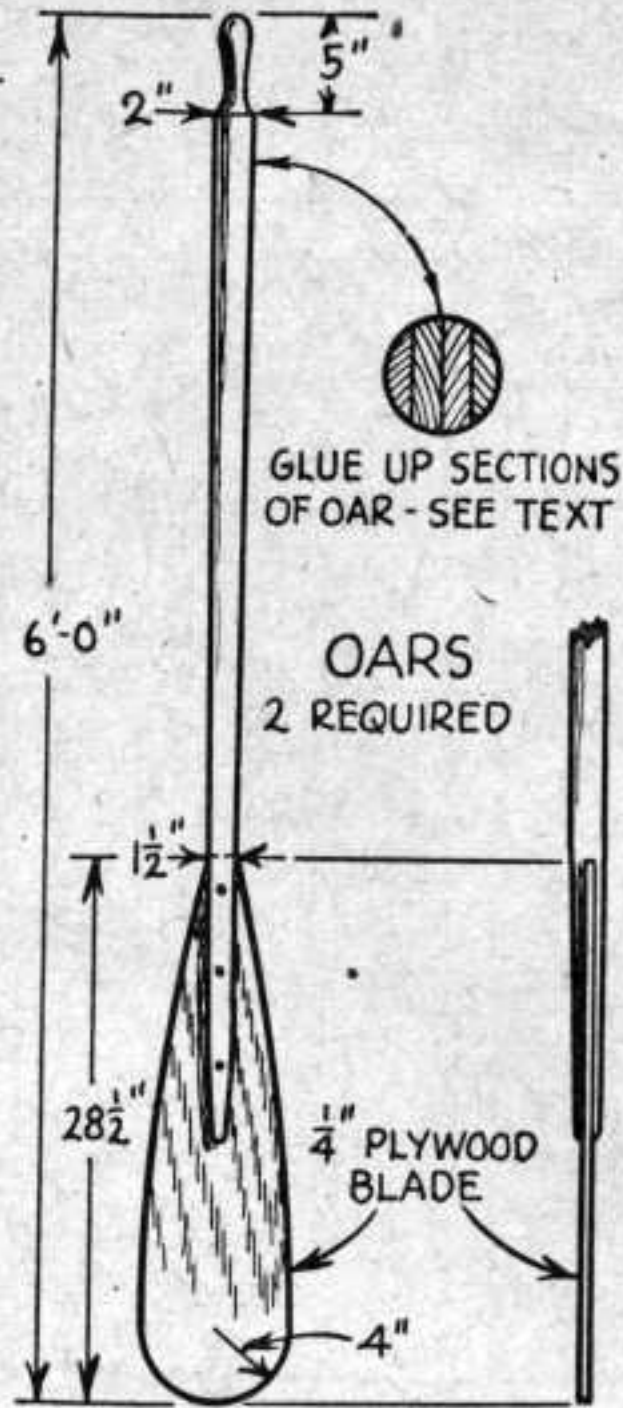
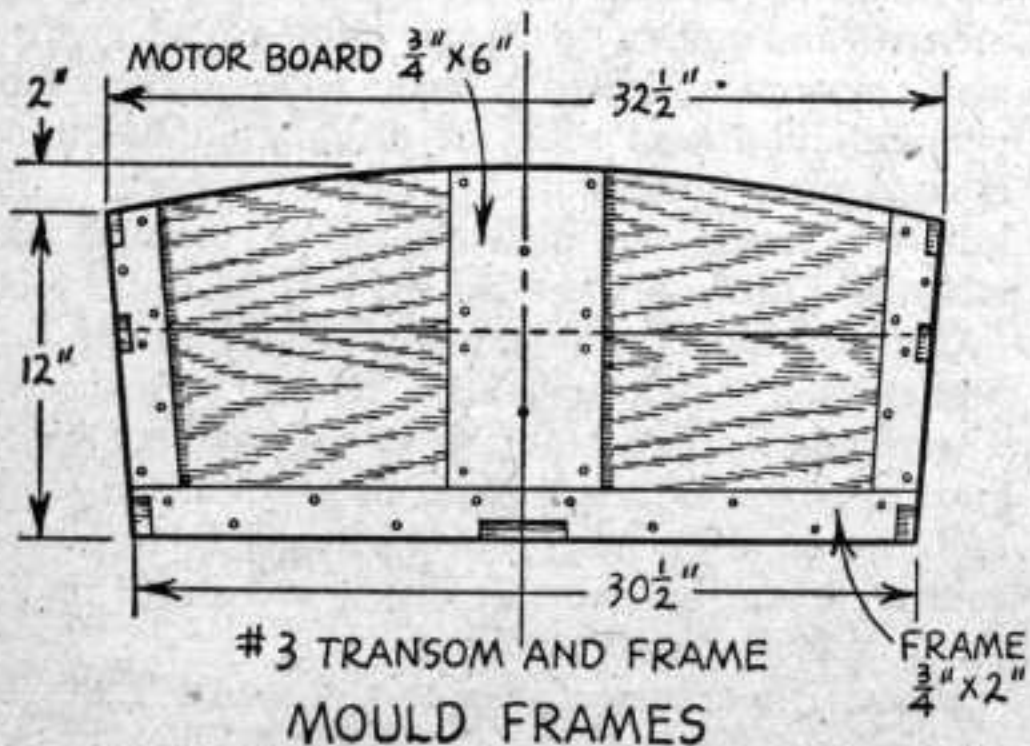
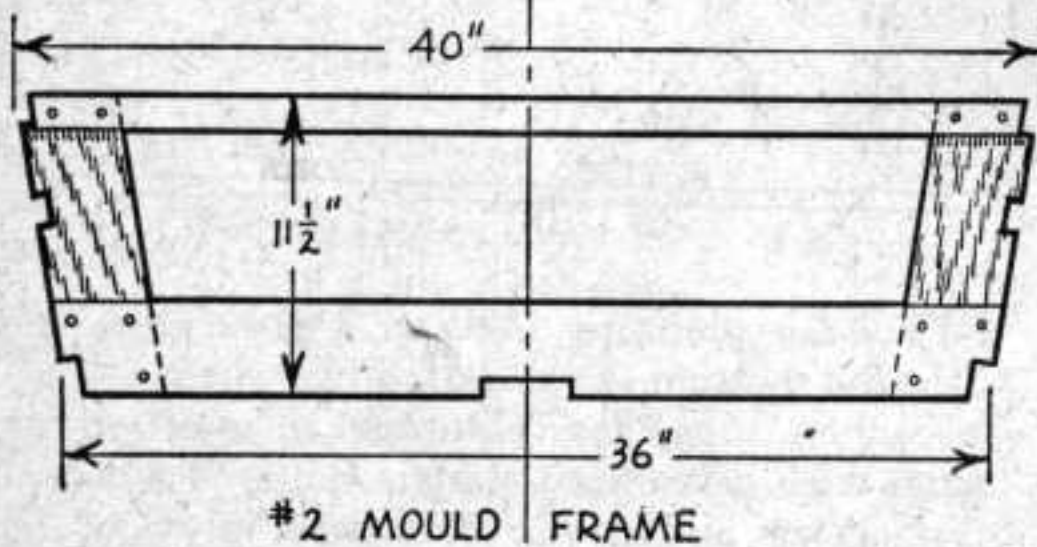
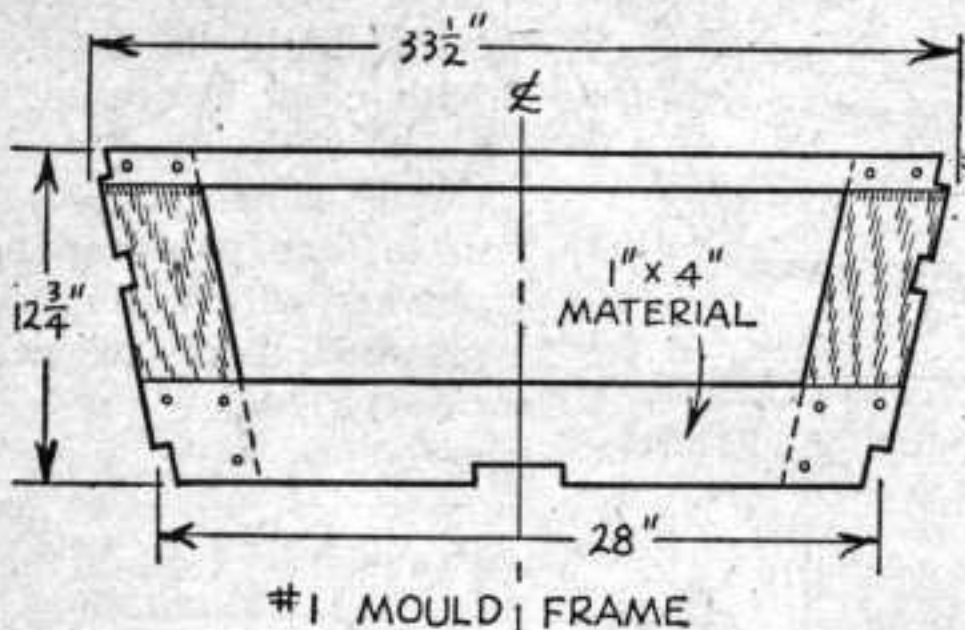

face of cloth should be filled with the same cement thinned with alcohol. Finish by painting any desired color. Now is the time to attach the outer keel, screw fastening in place with 1 1/4" No. 8 F.H. screws.

An excellent pair of lightweight oars are easily made for this boat by cutting blades from 1/4" waterproof plywood, while the handles are constructed of built-up wood strips 1/2" thick and glued with waterproof glue. When dry, plane handles to shape, sand smooth; notch lower ends

for plywood blade, glue and screw fasten, finish by painting or varnishing, and with the installation of oar locks we are ready for adventure.

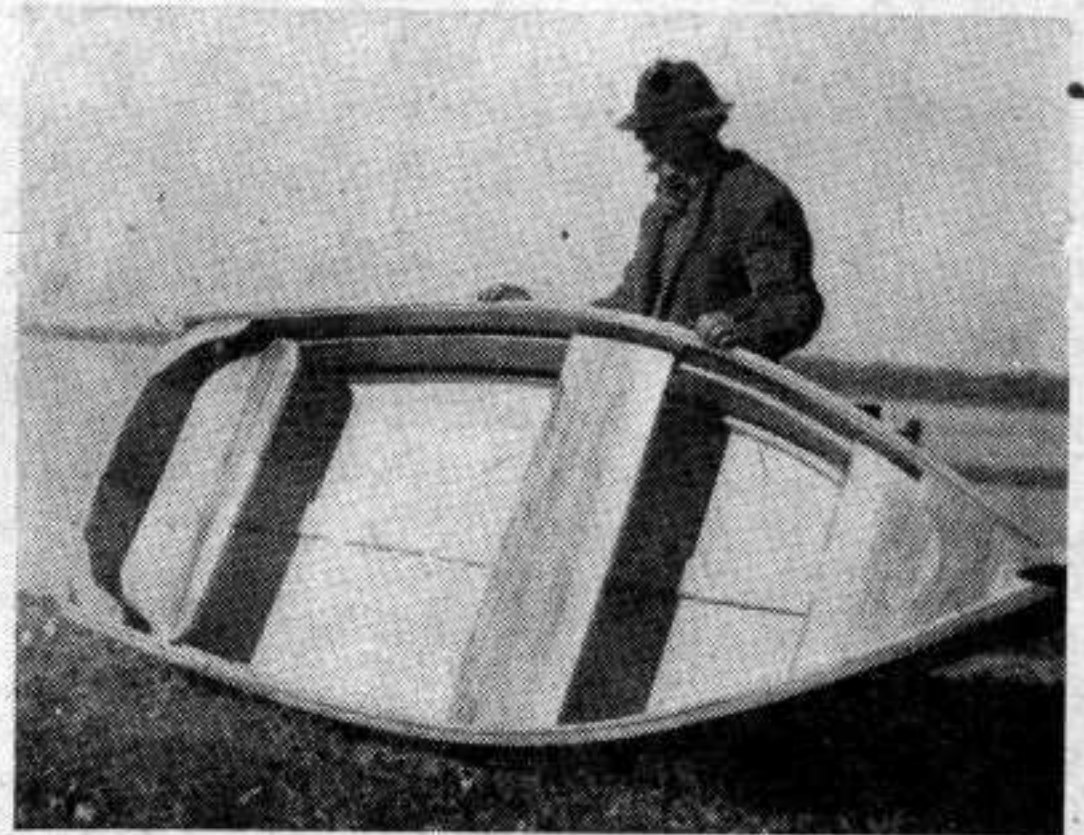

Completed boat, showing simple, sturdy construction.

● Craft Print No. 96 in enlarged size for building the "Jolly Roger" is available at 25c each. Address Craft Print Dept. B-48, SCIENCE AND MECHANICS, 49 East Superior St., Chicago 11, Ill.

Protection for Spark Plugs

TO reduce trouble from rain and snow on spark plugs of engines exposed to all kinds of weather, simply cover all exposed parts of the ignition system (especially the porcelain and metal parts of spark plugs) with a good coat of gasket shellac.—H. W. SWOPE.

