



Once you get the knack of handling a double paddle you'll be able to propel this kayak along the shallow waters of a river with less effort than it takes to walk.

## Shallow Draft Hunting Kayak

If you want to explore for game in the shallow back waterways (where noisy motorboats can't go), this two-seater is for you

By WILLIAM D. JACKSON

Craft Print Project No. 300

FOR many years a favorite of hunters, trappers and traders in this country, the kayak now is as popular with Europeans as the outboard boat is with Americans.

Although this boat was designed to carry two people, it will accommodate three in a pinch, and gear may be stowed under fore and after decks. A few strokes with the double paddle (Fig. 1) will send it gliding across the water with the minimum of effort on your part. Kayaks are surprisingly seaworthy, too—more stable than a canoe, in fact, because the occupants sit on the bottom of the hull which lowers the center of gravity.

Materials for building this kayak will run around \$25, and it will take about 25 hours of work if you are reasonably skilled in wood working. First make the building form, consisting of two A frames and a strongback, as in Fig. 3. Select a straight, well-seasoned 16 ft. 2 x 4 for the strongback and when laying out the tapered ends bend a 1/2 x 3/4-in. batten against nails driven at

measured points as in Fig. 3A.

If you have a portable jigsaw, cut strongback along the curved line, or saw straight and hand plane it to the curved line. Then lay out and cut the 3/4 x 1 3/4-in.

notches for the frames and saw off both ends at a 45° angle. Cut and toe nail the 2 x 4-in. stem blocks to the bottom of the strongback at each end to provide additional support for fastening the bow and stern stems to the strongback later. Now assemble the A frames to the strongback 56 in. on each side of center with nails.

You are now ready to start making the kayak hull framework which will be assembled upside-

### STATEMENT OF USES

**USES:** Two-place, flat-bottom kayak for hunting, fishing and general sports use on protected waters of small lake or river.

**LENGTH:** 18 ft.

**BEAM:** 40 in. to outside molding.

**DEPTH:** 11 in. sides.

**WEIGHT:** 100 lbs.

**CONSTRUCTION:** Exterior sheet plywood over wooden framework.

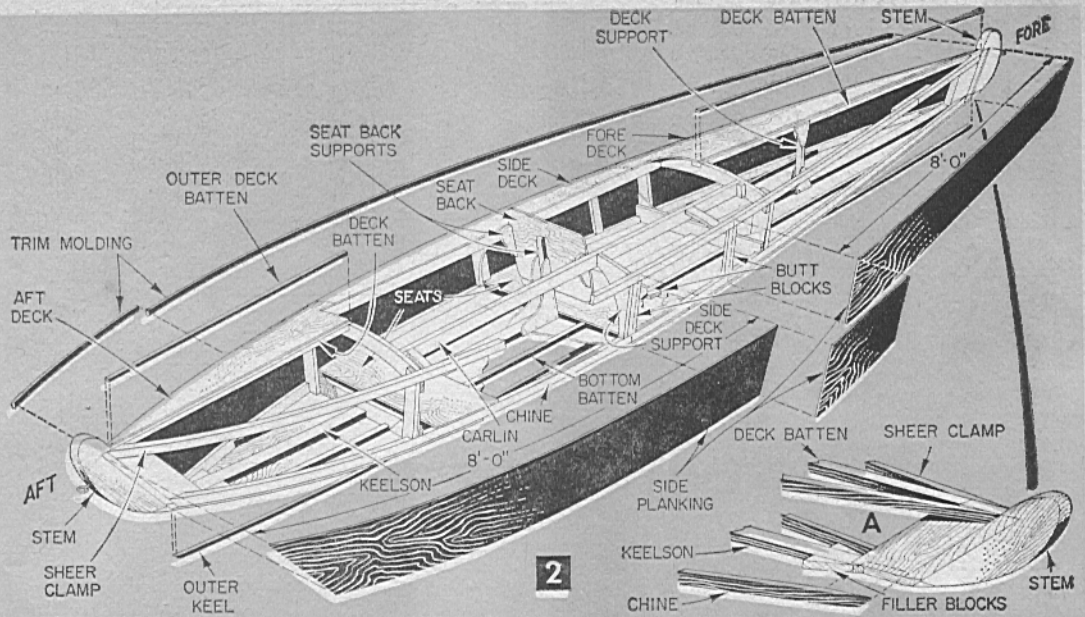

down on the building frame.

Starting with the stems (Fig. 3B), make a full-size drawing of one on heavy paper and cut it out. Using it as a pattern for both stems, place it on the wood and draw around. After cutting the stems to shape with a jig or handsaw, again place the paper pattern on the stems and mark the location of the rabbet and bearding lines on each side of the stems with a series of nail point marks.

To cut the rabbet, first score along the rabbet line with a knife held at approximately a 10° angle. Make several passes with the knife to

make the cut 1/4 in. deep. Then use a 1-in. chisel to cut the beveled rabbets along the bearding lines. Note in Fig. 3B that the bow stem has a wider rabbet than the stern stem.

After cutting the rabbets, bevel the fore end of the sides with a plane until the center of the curved leading edge is 5/8 in. thick. Fasten the stems to the ends of the strongback with 3 x 7-in. pieces of 1/4-in. plywood temporarily nailed on each side as in Fig. 3. Do not use screws because these pieces must be taken off to remove hull from building frame when completed.

Make up the frames (Fig. 4) next. Numbers

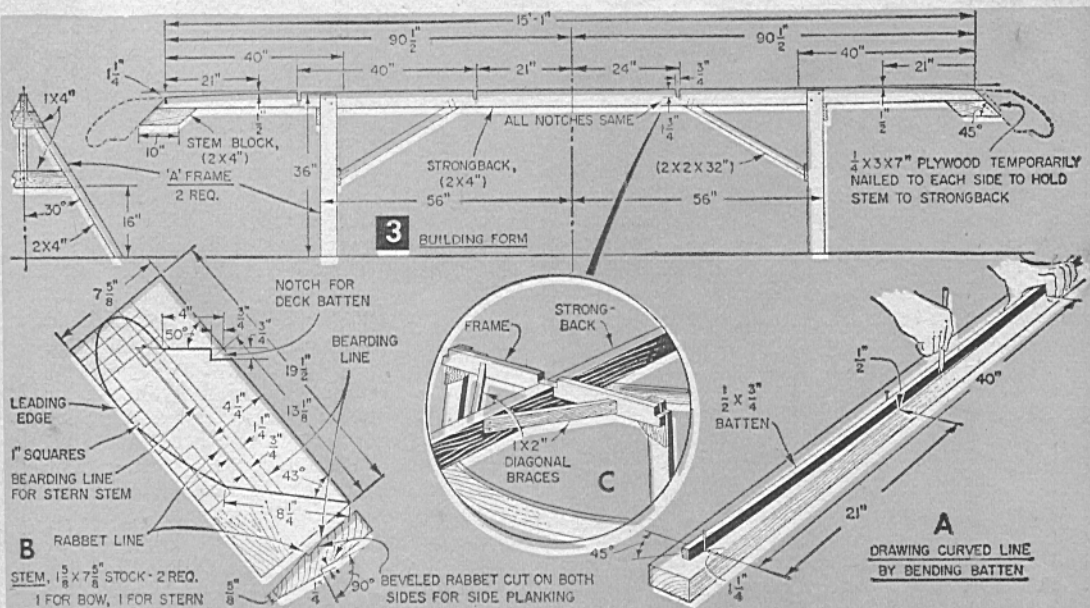

1 and 3 frames are permanent frames, and remain in the boat when finished. The #2 mold frame is removed from the hull just before the decking is installed.

First make a full-size drawing of each frame (Fig. 1) on wrapping paper. Transfer the outline of each frame piece by placing the wood it is to be cut from under the paper pattern and punching a series of indentations along the drawn lines with a nail or toothed wheel such as a dressmaker's or leather crafter's wheel. After removing the pattern, draw pencil lines along indentations and saw to marked shape.

**Assembling the Frames.** Place the frame pieces in their respective places on the paper drawings so that they will be properly positioned in relation to one another. Fasten the mold frame together with nails, and use waterproof glue, 1-in. nails and #8 x 1 $\frac{3}{4}$ -in. fh screws on frames #1 and 3. Note in the end view of #1 and 3 frames (Fig. 4), that the  $\frac{1}{4}$ -in. plywood gussets are placed between the bottom and side frame members.

Do not fasten the curved deck beams to #1 and 3 frames at this time. When the glue has dried, cut notches on all frames for chine, keel and sheer clamps as dimensioned on #1 frame. Then place the frames into the notches cut in the building frame strongback, center and square them, and fasten with 1 x 2-in. diagonal braces temporarily nailed in place (Fig. 3C).

Next, rip saw the 2-in. wide keelson and 1 $\frac{1}{4}$ -in. wide chines and sheer clamps from a single 18 ft. length of 1 x 8-in. fir stock. If you have trouble locating an 18-ft. length (16 ft. is the longest stocked by many yards), use a 16-ft. length and add a short piece on the end. Back up the added piece for the sheer clamps with a 10-in. length of the same size stock as in Fig. 5. No back-up piece is needed on keelson and chines. Use a combination circular-saw blade for ripping this stock so you will not have to plane the saw-cut edges smooth.

Fit the keelson in the frame notches and draw the ends down against the strongback with C-clamps. If everything fits well, remove the keelson, coat frame notches and stems with glue and reinstall the keelson, fastening with two #8 x  $\frac{3}{4}$ -in. fh screws to frames and stems (but not to mold frame #2). Plane the ends flush with the stem sides.

**Installing the Chines.** Temporarily bend and clamp the chines in the notches cut in the frames. You will notice that the notches on the #1 and 3 frames will have to be beveled slightly for a good snug fit with the chines. This you can do quite easily by running a handsaw between the chines and frame notches. Several cuts may be needed

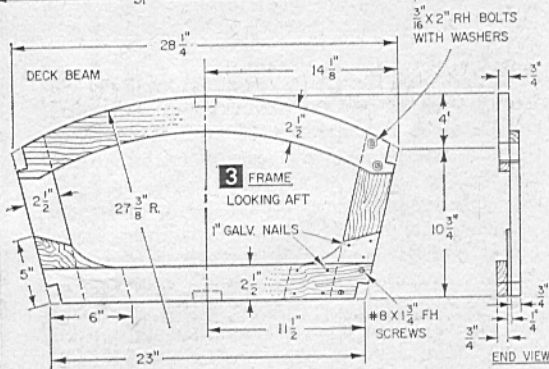
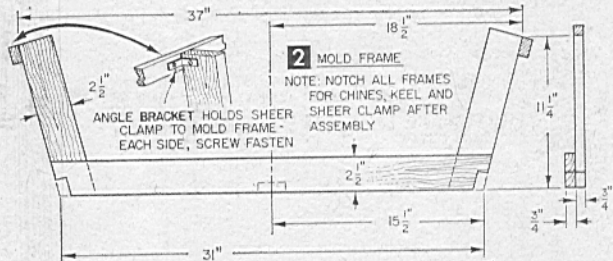
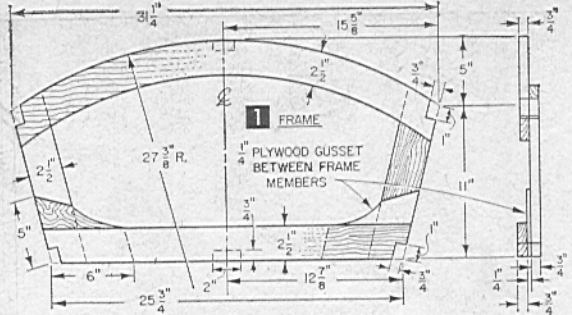

to completely bevel the frame notches. With the chines still clamped in place, mark the ends for tapering so that they will fit snugly against the keelson and stems.

When sawing the chine ends, cut them slightly oversize so you will have stock left for trimming to the exact angle of taper. Mark and cut the filler blocks (Fig. 2A) and fasten with glue and screws to the sides of the keelson. Fasten the chines to the stems, filler blocks and #1 and 3 frames with glue and one #8 x 1 $\frac{3}{4}$ -in. fh screw at each frame and two screws at the stems. Toe nail the mold frame to the chines so the nail heads will be on the inside of the hull and can be removed later.

Follow the same procedure used when fitting and fastening the chines when installing the sheer clamps (Figs. 2 and 3). Cut notches in the bottom frame members to take the  $\frac{3}{4}$  x 1-in. bilge battens and fasten to #1 and 3 frames and chines with glue and #8 x 1 $\frac{3}{4}$ -in. fh screws. Do not fasten to the mold frame.

The most difficult part of the framing is now over and you are ready to fair the framing mem-

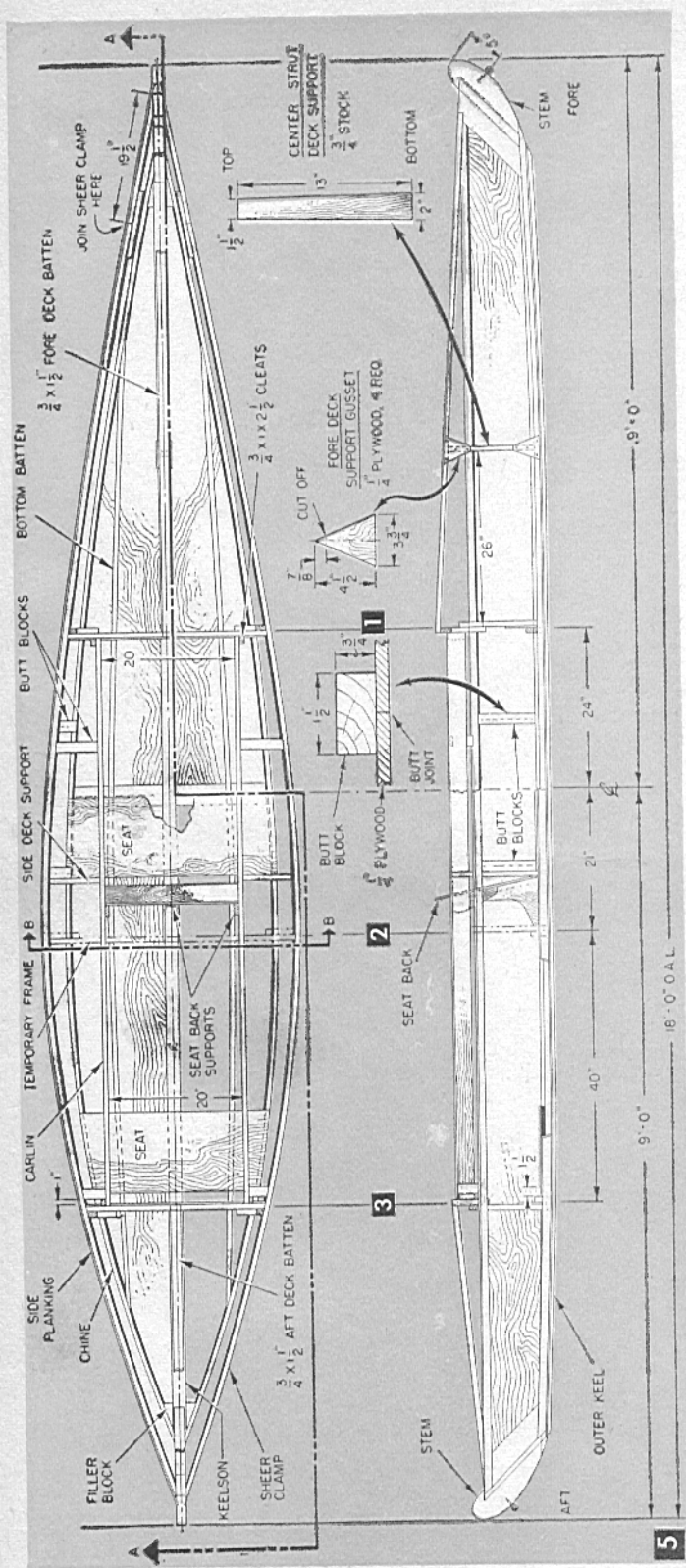

bers flush with one another so the plywood covering will make good gluing contact. Use a jack plane and large wood rasp for fairing. Sighting along the bottom edge of a straight edge held across the adjoining frame members will indicate the high and low spots.

**Planking the Bottom.** One 4 x 8-ft. panel of 1/4-in. plywood will cover the entire bottom when cut as in Fig. 8. Place the plywood panel on the fore end of the framework first, centering the 4-ft. ends along the keelson. Then pencil mark it on the underside along the chines. Remove and cut to shape with a portable jigsaw. Use the two cut-off pieces of plywood to plank the aft end of the bottom joining them along the keelson as in Fig. 9. Fasten with glue and 7/8-in. serrated boat nails or #6 x 1-in. fh screws spaced 2 in. apart. Do not fasten to mold frame. Where the fore and aft planking join, place a 3/4 x 2-in. butt block between keelson and chines (Fig. 5) on the inside of the hull and fasten with glue and nails or screws. When the glue has dried, plane the edges of the plywood flush with the sides of the chines.

Cut four 14 in. wide pieces of 1/4-in. plywood as in Fig. 8, and two 13 x 24-in. plywood pieces to plank both sides of the hull. The two 13 x 24-in. pieces are fitted between the 8-ft. lengths amidships as in Fig. 2. Start by applying the four long lengths to the fore and aft ends, carefully cutting and fitting them into the rabbets on the stems. Instead of glue use *Tarp Seal*, a neoprene sealer, on all contact surfaces and fasten with screws or nails as you did the bottom planking. Carefully fit the 20-in. lengths amidships, using 3/4 x 1 1/2-in. butt blocks between chines and sheer clamps to back up the vertical seams. Then plane the edges of the plywood flush with the bottom planking, and remove the hull from the building form. Turn it right side up and place upon saw horses so it will be at a convenient working height.

Now take the previously cut deck beams for the #1 and 3

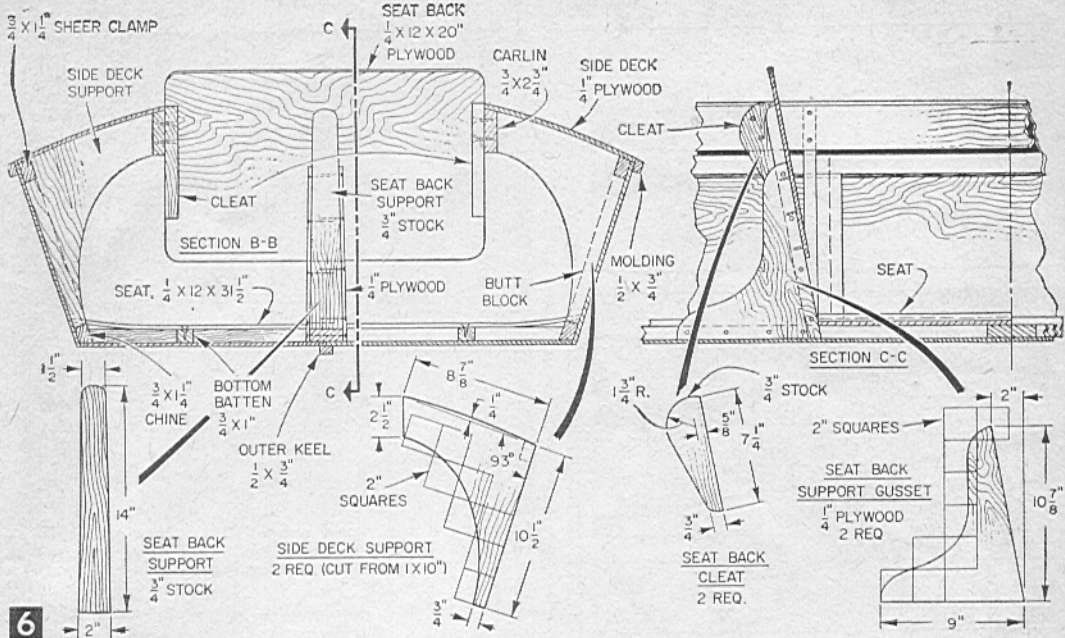

6

frames and fit and fasten them to the frames with glue and two  $\frac{3}{16}$  x 2-in. rh bolts at each side as in Fig. 4. Use washers under bolt heads and nuts. With these members in place, knock out the mold frame and remove it.

Fore and aft deck battens (Fig. 5) are next. Notch them flush into the deck beams and stems, and fasten with one #8 x 1 $\frac{3}{4}$ -in. fh screw at each joint. Reinforce the fore deck batten with a strut extending from batten to keelson (Fig. 5). Fasten strut with  $\frac{1}{4}$ -in. plywood gussets glued and nailed in place.

**Deck Supports.** To support the side decks and carlins amidships, make up two deck support pieces from  $\frac{3}{4}$ -in. solid stock (Fig. 6). Assemble them inside the hull and against the aft side of the butt blocks nearest the stern (Fig. 5). Fasten with glue and #6 x 1-in. fh screws driven through from the outside of the side planking.

Rip two carlins (Fig. 6) from a single length of 1 x 6-in. stock 7 ft. long. Fit them between the #1 and 3 frame deck beams and against the side deck supports. Allow the top edges of the carlins to project above the deck beams slightly, so they can be beveled to conform with the curvature of the deck beams. Fasten ends of carlins to deck beams with  $\frac{3}{4}$  x 1 x 2 $\frac{1}{2}$ -in. cleats and #8 x 1 $\frac{3}{4}$ -in. fh screws. Drill pilot holes for screws to avoid splitting the cleats. Use two #8 x 1 $\frac{3}{4}$ -in. fh screws to fasten carlins to side

MATERIALS LIST—KAYAK

No. Reqtd.	Size and Description	Use
2	$\frac{1}{4}$ " x 4' x 8' AC grade exterior fir	bottom and sides
1	$\frac{1}{3}$ " or $\frac{1}{4}$ " x 4' x 8' A-A exterior mahogany or fir	decking
1	$\frac{1}{4}$ " x 4' x 8' A-A grade exterior fir	seats, gussets, sides
	Lumber	
1	$\frac{3}{4}$ " x 7 $\frac{5}{8}$ " x 18' fir or spruce	keelson, chines, shear clamps
1	$\frac{3}{4}$ " x 5 $\frac{5}{8}$ " x 16' fir or spruce	carlins and frames
1	$\frac{3}{4}$ " x 3 $\frac{5}{8}$ " x 12' fir or spruce	deck and bottom battens
1	$\frac{3}{4}$ " x 3 $\frac{5}{8}$ " x 16' fir or spruce	molding and outer keel
1	$\frac{3}{4}$ " x 9 $\frac{5}{8}$ " x 8' fir or spruce	deck beams and side deck supports
1	1 $\frac{5}{8}$ " x 7 $\frac{5}{8}$ " x 36' fir or spruce	stems
2	1 $\frac{5}{8}$ " x 3 $\frac{5}{8}$ " x 16' fir or spruce	building form
	Fastenings	
2 lbs.	#12 x $\frac{7}{8}$ " stronghold boat nails or	
4 gross	#6 x 1" fh galv. screws (if above nails are not used)	
6 doz	#8 x 1 $\frac{3}{4}$ " fh galv. screws	
2 doz	#8 x 1 $\frac{1}{4}$ " fh galv. screws	
4	$\frac{3}{16}$ " x 2" rh zinc-coated stone bolts with 8 washers	
2	$\frac{3}{16}$ " screweyes	
1 pt	Tarp Seal or equivalent	
1 lb	Weldwood glue	
1 qt	Firzite (white)	
1 qt	spar varnish	
1 qt	marine enamel	

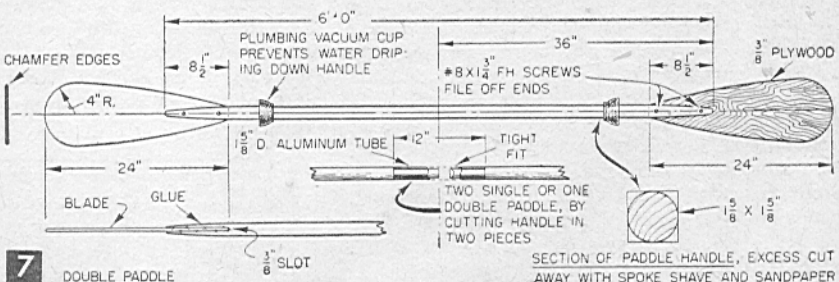

7

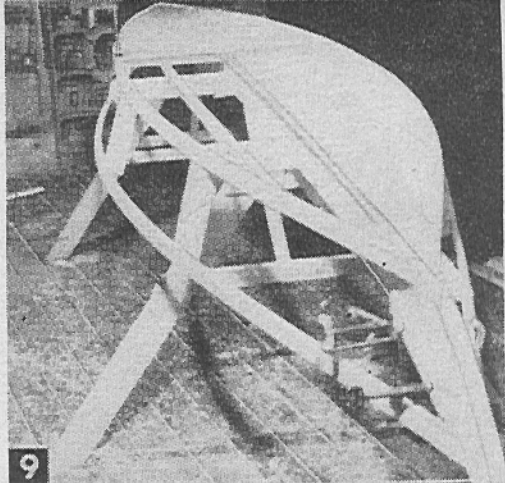
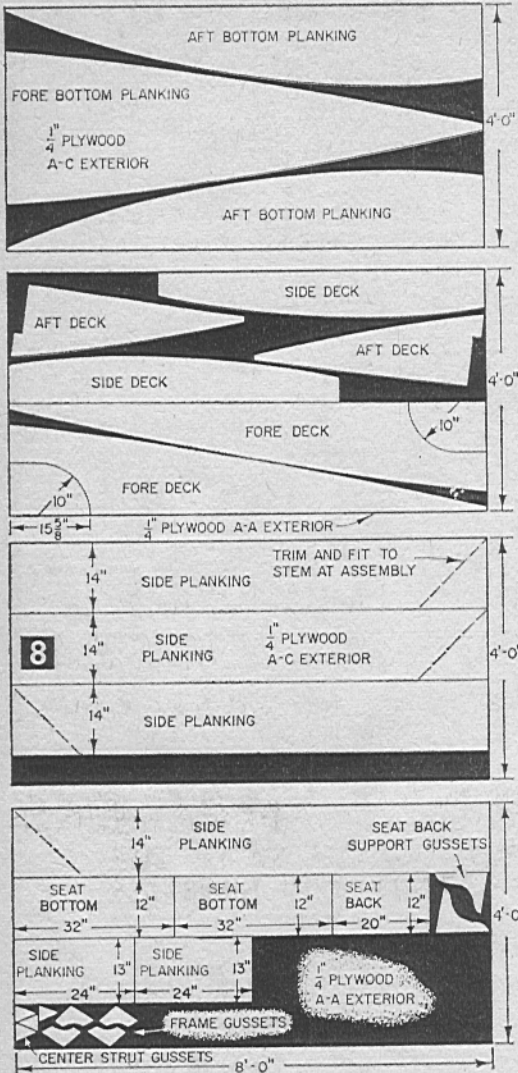

One 4 x 8 ft. plywood panel cut into three pieces as in Fig. 8 covers entire bottom. Half of aft end remains to be covered here.

deck plywood flush along the sheer and carlin and install a  $\frac{1}{2} \times \frac{3}{4}$ -in. molding along the sheer (Fig. 6), fastening with #6 x 1-in. *fh* screws spaced 6 in. apart. Cover the center seam on the fore and aft deck with a  $\frac{1}{2} \times \frac{3}{4}$ -in. batten having a concave bottom shaped on a circular saw. Fasten with #8 x  $\frac{1}{4}$ -in. *fh* screws spaced 6 in. apart. Use a  $\frac{1}{2} \times \frac{3}{4}$ -in. strip for the outer keel (Fig. 6).

**Two Seats.** Make these from  $\frac{1}{4}$ -in. plywood 12 in. wide and fit each one in the hull so that the seats extend across from chine to chine. Fasten to keelson, battens and chines with three #6 x 1-in. *fh* screws in each member. Only the forward seat has a back rest; the rear of the cockpit serves as a back rest for the aft seat. Make the back rest for the forward seat from  $\frac{1}{4}$ -in. plywood and install between the carlins with the center support and cleats (Fig. 6).

Finish the outside of the hull with three coats of white *Firzite* followed by one coat of marine enamel of the color desired. If you have used mahogany plywood for the decks and seat back, apply three coats of spar varnish for a natural wood finish. Insert  $\frac{3}{16}$ -in. screweyes in the fore and aft stems for mooring ropes.

**Making the Paddles.** The shafts for two double paddles can be ripped from the 2 x 4-in. stock used for the building form strongback. Round the shafts with a spokeshave and sand smooth. Slot the ends for the  $\frac{3}{8}$ -in. paddle blades as in Fig. 7, and fasten blades to shaft with glue and #8 x  $1\frac{3}{4}$ -in. *fh* screws. Then saw off projecting ends of screws, and give paddles three coats of varnish.

deck supports.

Now, give the entire interior of the hull two coats of white *Firzite* followed by one coat of marine enamel of your color choice. Do not paint the top edges of the deck beams, battens or sheer clamps, since the decking will be glued to these members. Fair off the top edges of the framework members with jack plane and rasp so that they will make good contact with the decking.

**Decking.** The original kayak was decked with  $\frac{1}{8}$ -in. mahogany plywood. If this is not available in your area, use  $\frac{1}{4}$ -in. plywood, which will only increase the weight of the boat about 12 lbs. In either case, by carefully marking the fore, aft and side decks pieces as in Fig. 8, the entire hull can be covered with one 4 x 8-ft. panel of plywood. Fasten the deck plywood to framework with glue and #6 x 1-in. *fh* screws spaced  $2\frac{1}{2}$  in. apart. Use butt blocks under side decking seams.

After the glue has dried, plane the edges of the

● Craft Prints in enlarged size for building canoes, duck boats and kayaks are available at \$1.50 each. Order by print number. To avoid possible loss of coin or currency in the mails we suggest you remit by check or money order. (No C.O.D.'s or stamps.) Now available, our new illustrated catalog of "196 Do It Yourself Plans," 10¢. SCIENCE AND MECHANICS, 450 East Ohio Street, Chicago 11, Illinois. Please allow three to four weeks for delivery.

