

Altered Minimax

Made some minor alterations in this *Minimax* (Craft Print 255). I used $\frac{3}{8}$ instead of $\frac{1}{4}$ -in. plywood on the motor board and also strengthened it with carriage bolts through the motor board and transom pad. I replaced the keelson with a racing fin, and raised the motor board to $17\frac{1}{2}$ inches.

With a 12 *hp* Royal and a high speed propellor she has been clocked at 38-42 *mph*.

Total cost of boat including steering wheel and





With a 10 hp outboard motor Minimax skims across the water at 15 mph. Air compartments make it unsinkable.

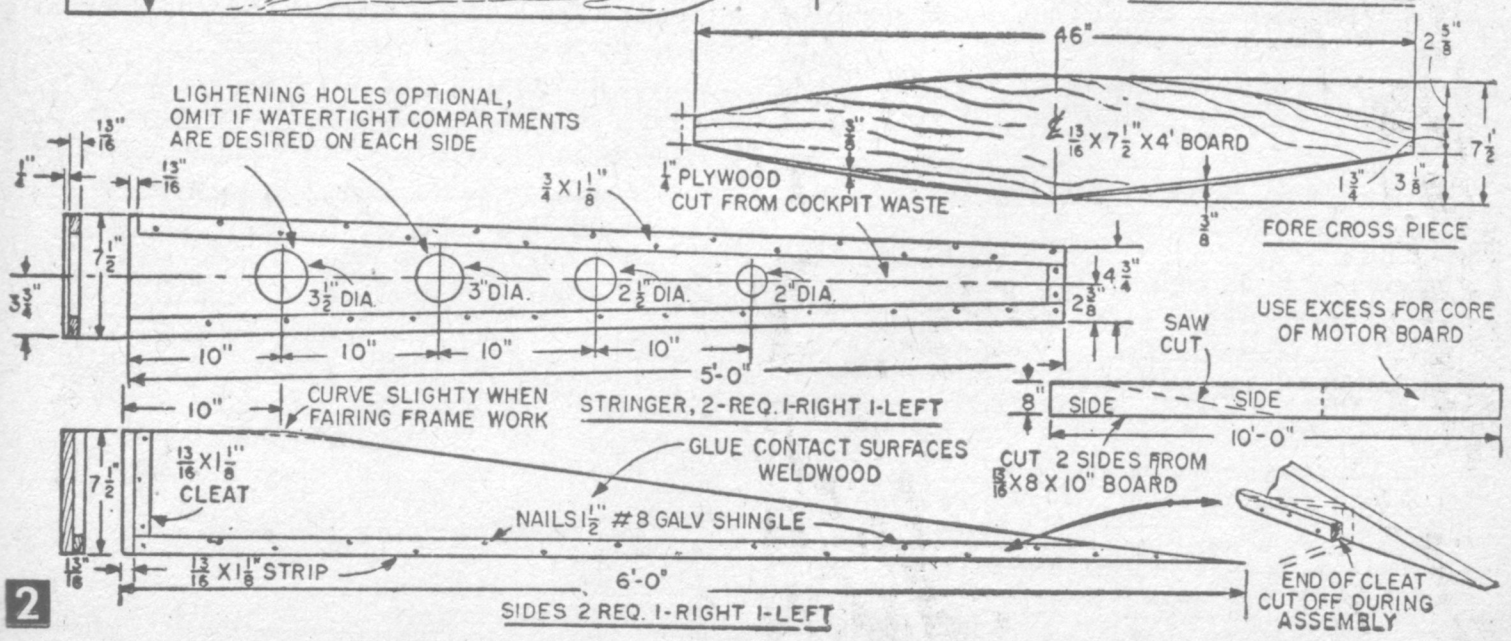
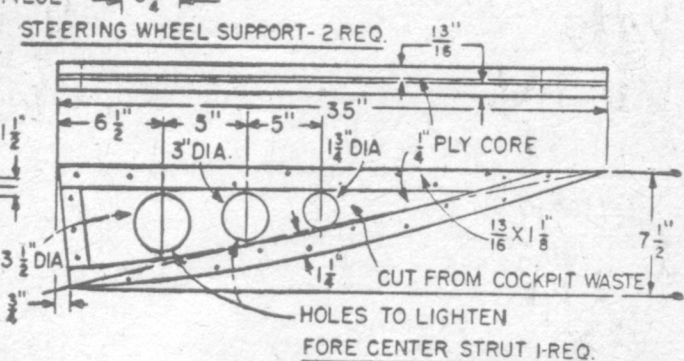
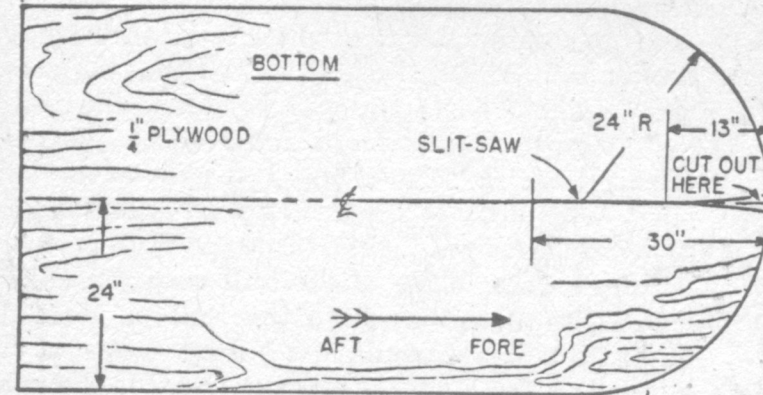
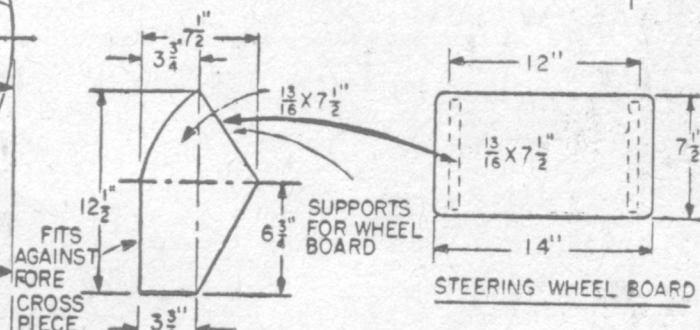
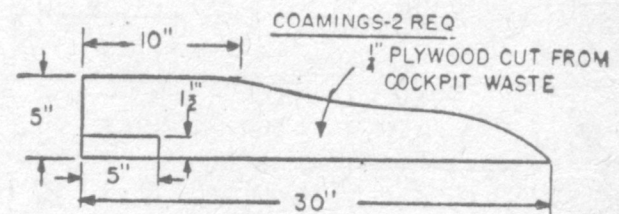
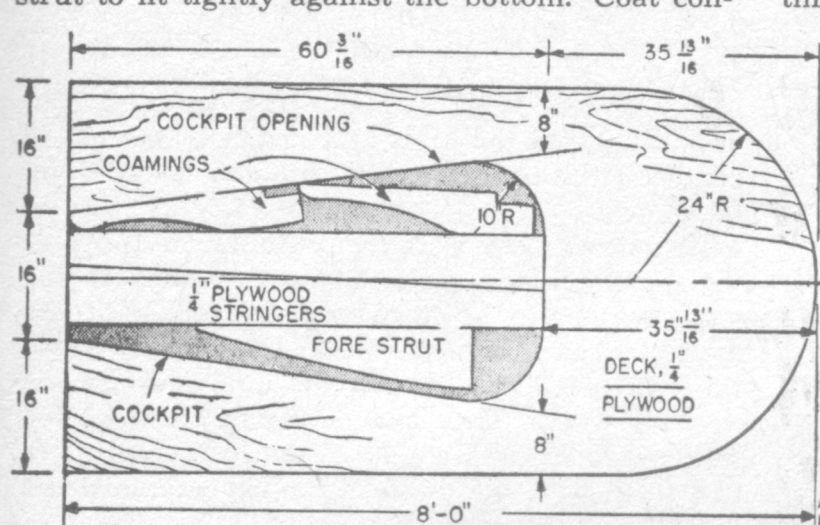

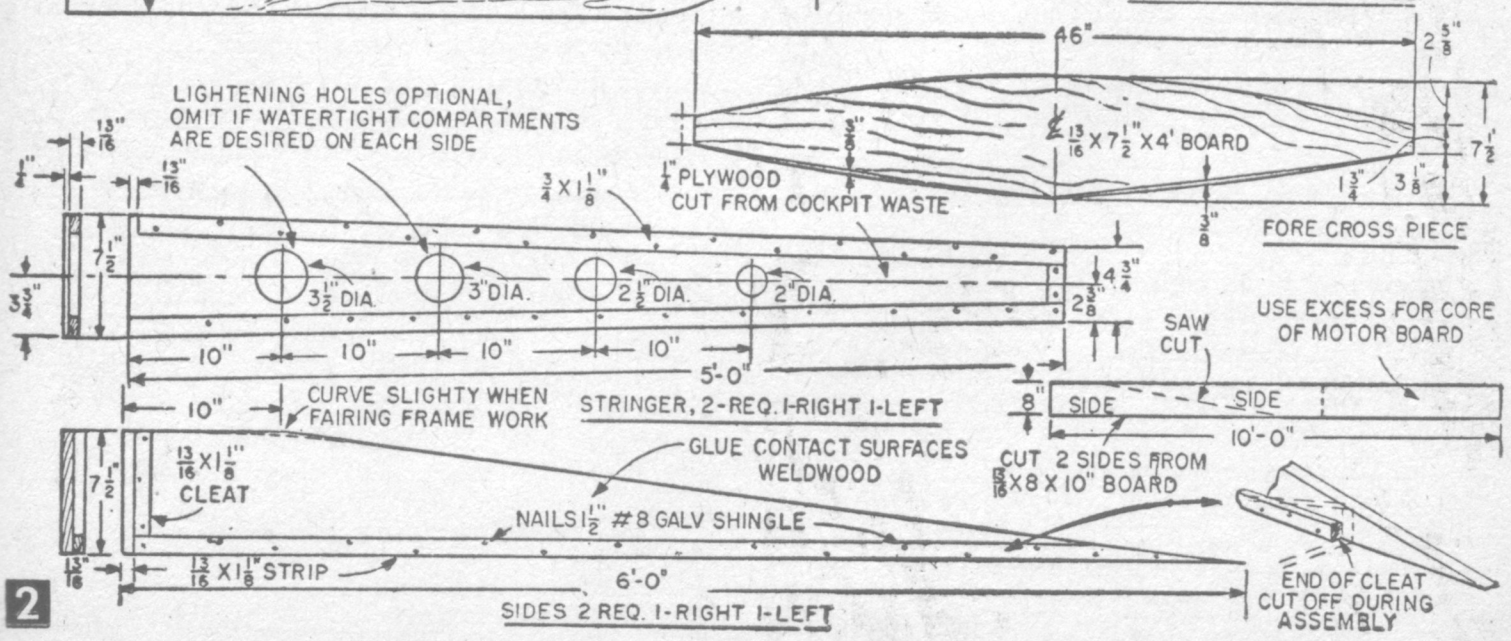
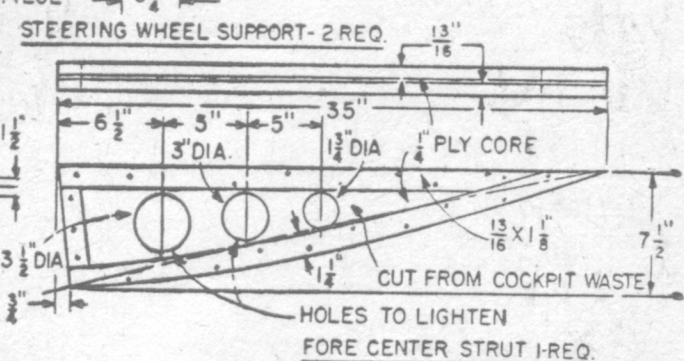
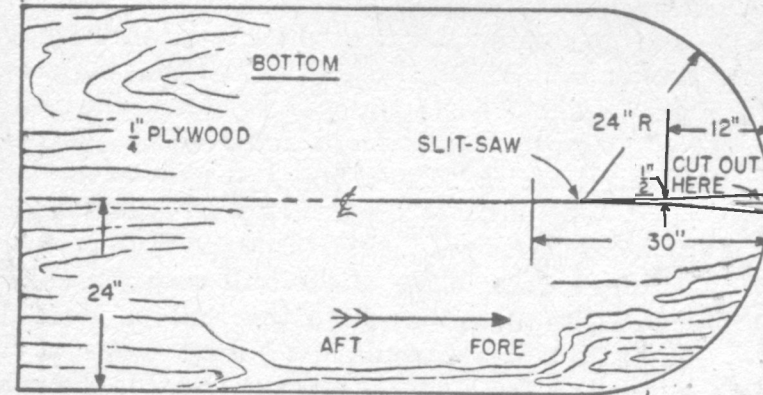
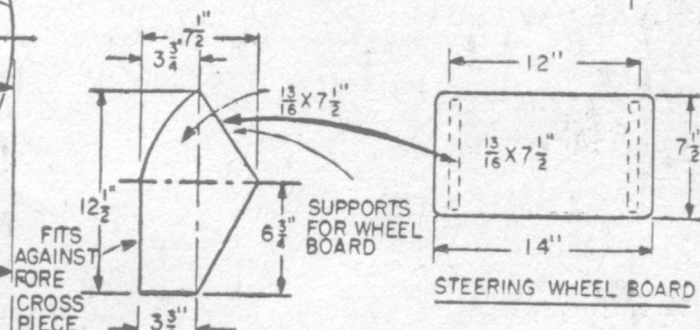
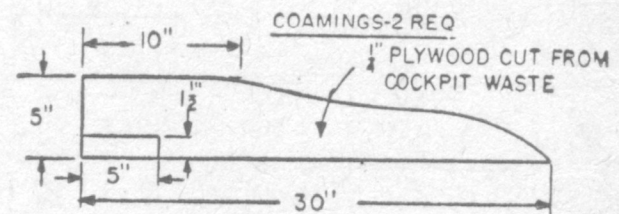
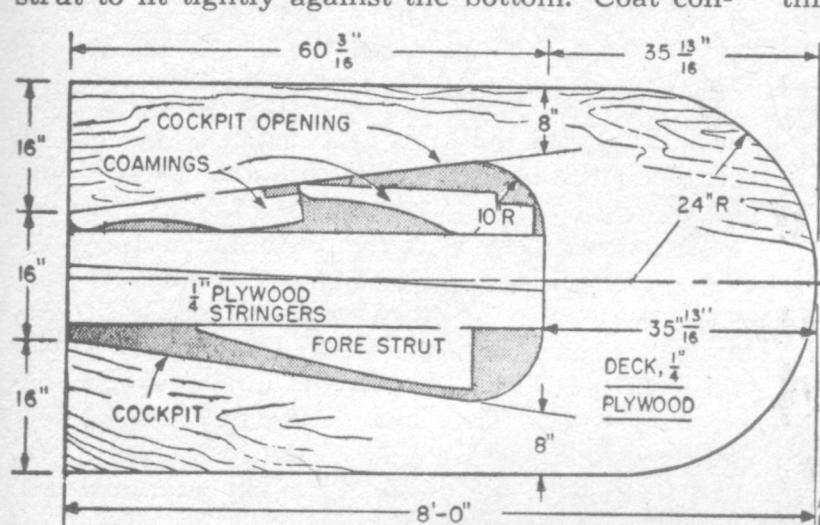

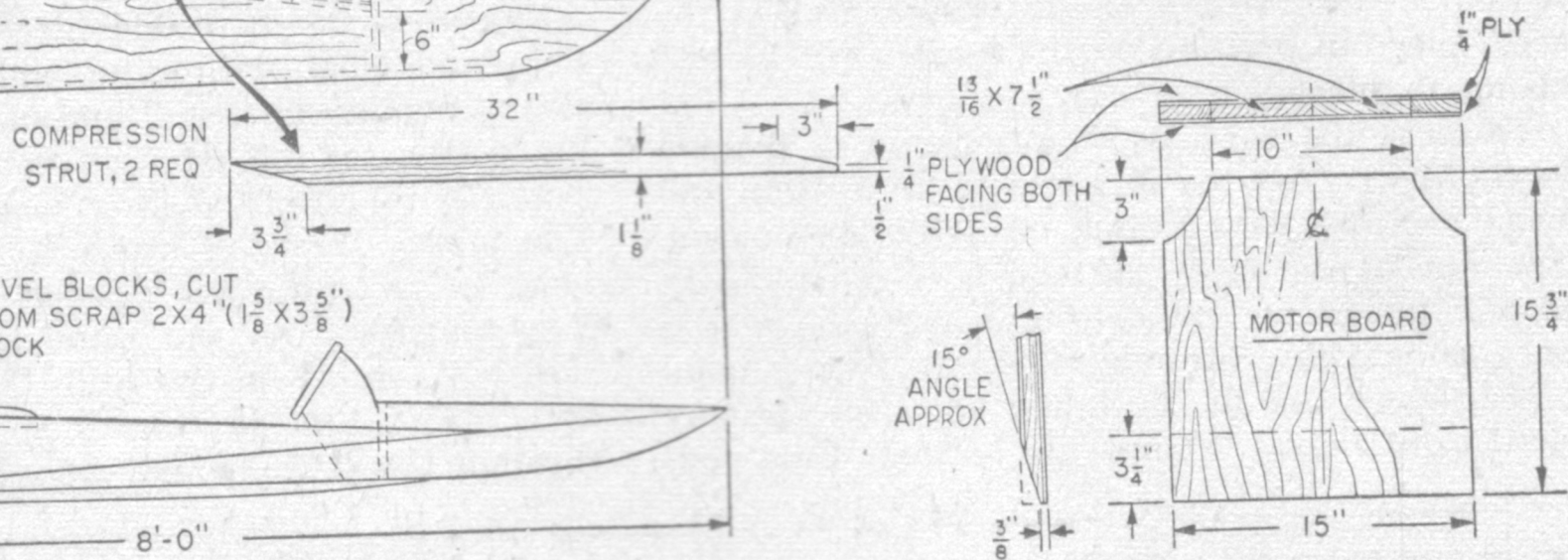
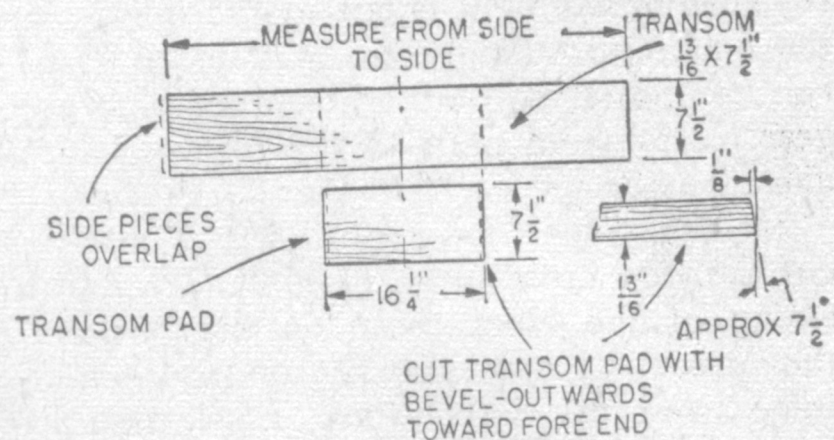
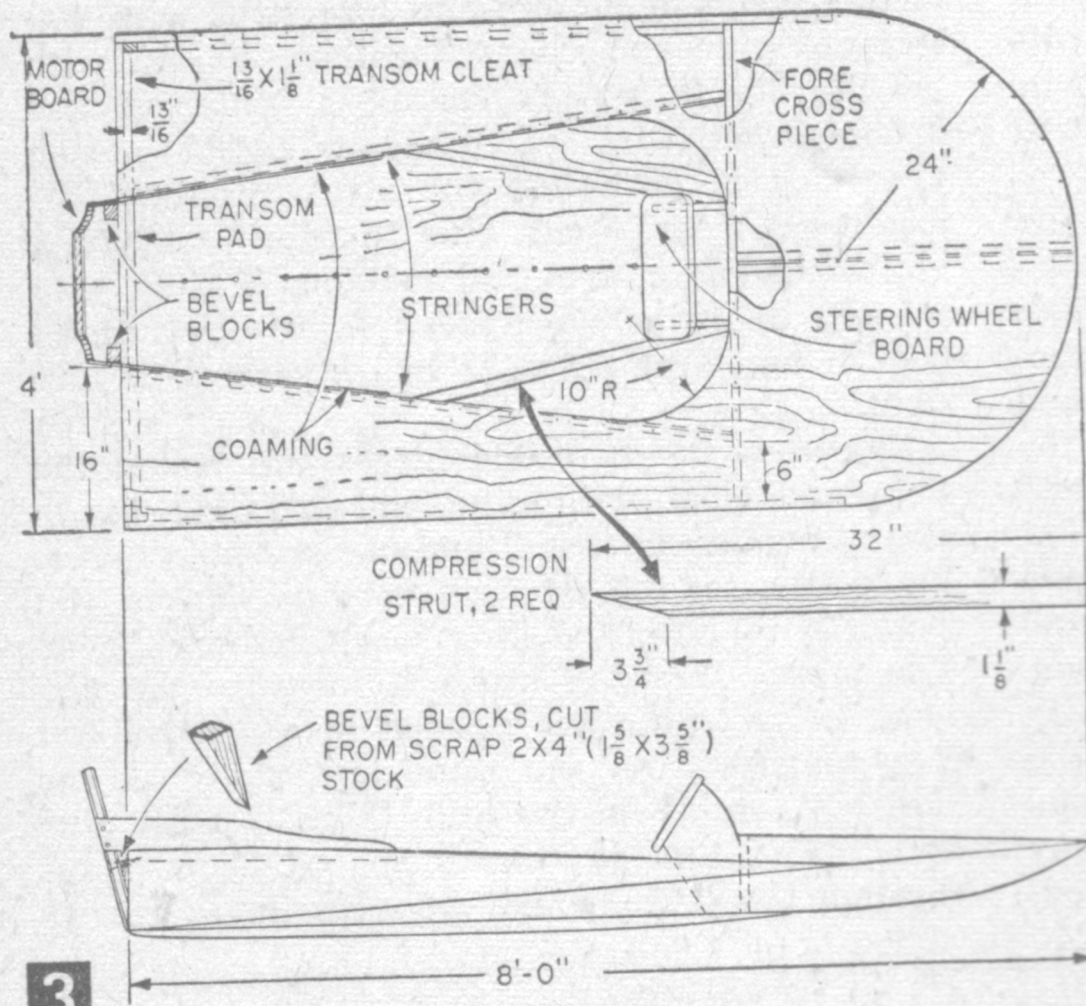

3

into the side cleats. Make the transom pad (Fig. 3), bevel the ends and fasten to the inside with glue and #6 x 1 1/4 in.

inside of the watertight fore compartment and

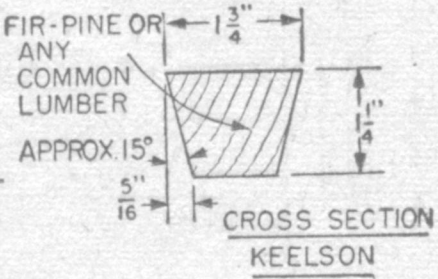
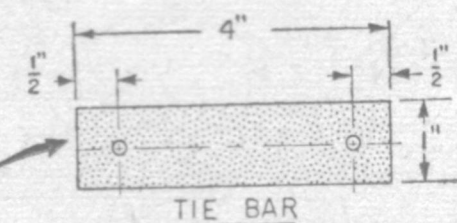
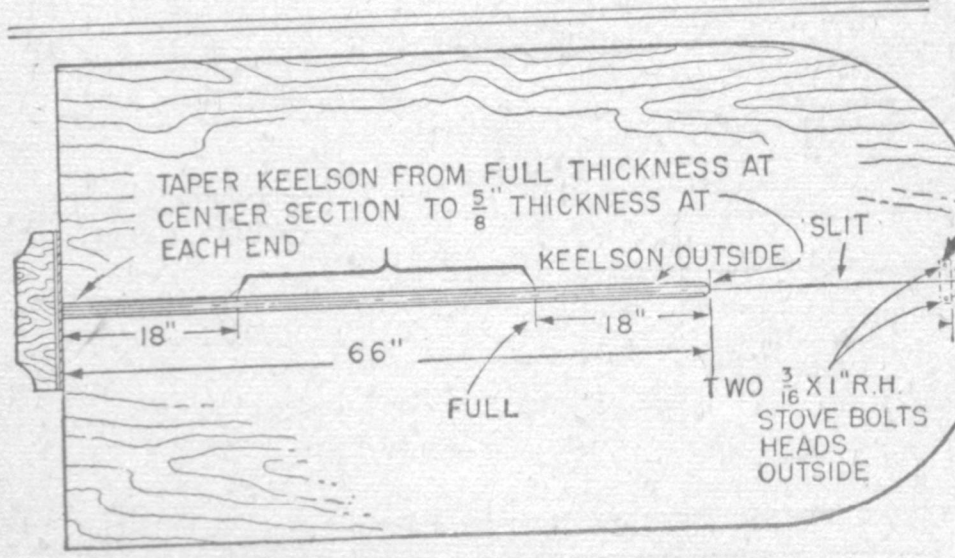

STRIP OF 16 GAGE STRAP IRON TO HOLD SLIT TOGETHER WHILE HULL IS BEING SHAPED

INSIDE-BEND TO FIT

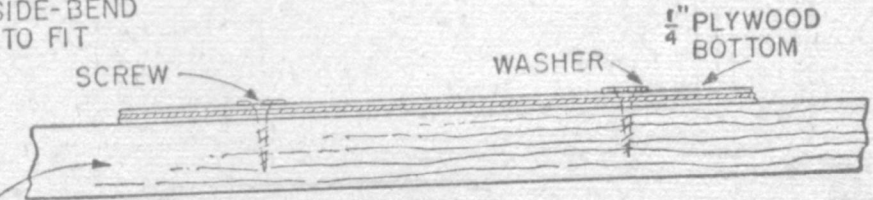

HOW KEELSON IS FASTENED TO PLYWOOD BOTTOM

PROCEDURE

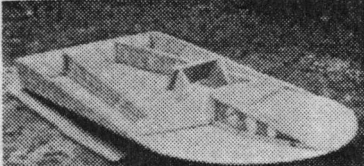

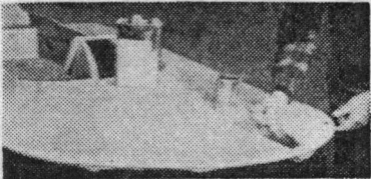

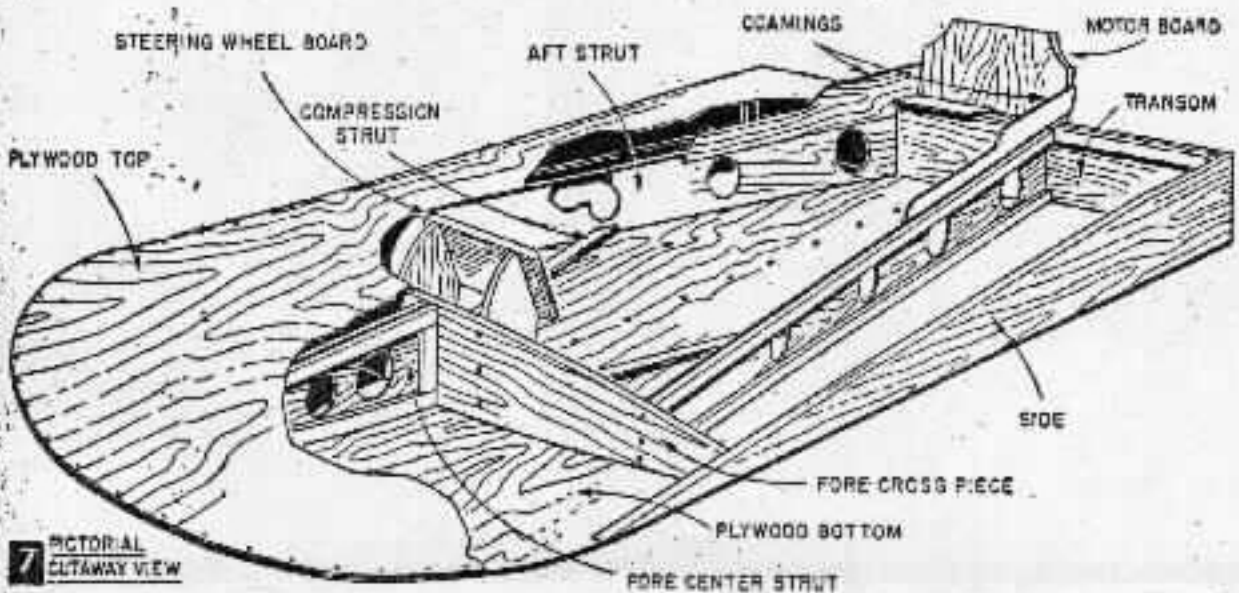

MINIMAX

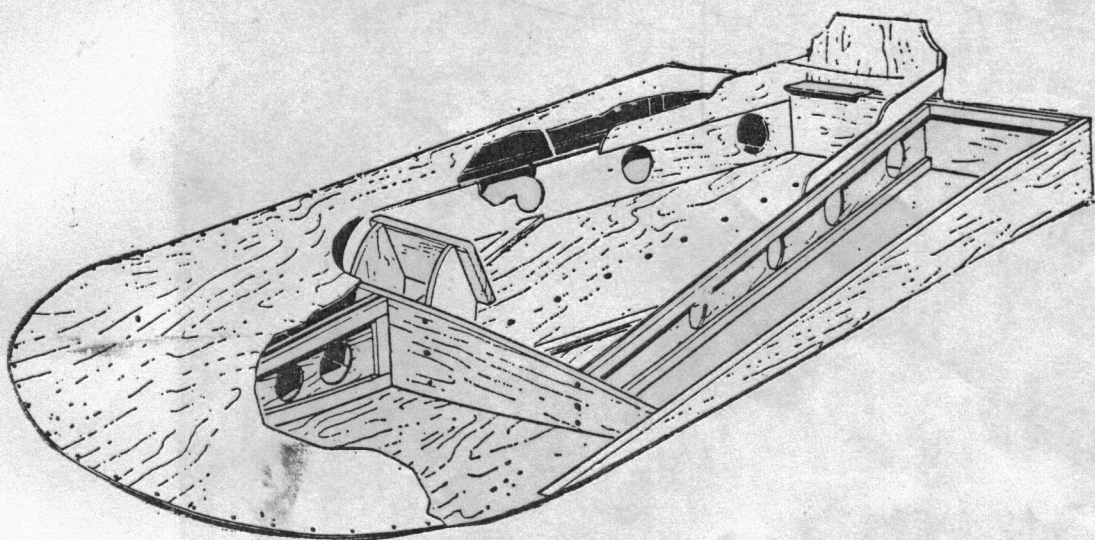

Most boat for the least money is this happy little hot rod racing dish. One weekend of work, or even one day if you're experienced, will have you ready for the water for under \$20. Clamp on a small outboard, and go....

■ Minimax is exactly what the name implies—a boat requiring the minimum in time and material to build to give you the maximum in performance and water-sport fun. Actually, Minimax was built in one day at a cost of \$20. It will carry two people, take outboard motors ranging from 3 to 15 *hp*, has a watertight air compartment that will support 900 lbs. even with the cockpit completely filled with water.

As to performance, Minimax will plane a 165 lb. man up to 15 *mph* with a 3 *hp* outboard motor. With 10 *hp* and over (Fig. 1), the hull planing area diminishes until Minimax becomes air-borne and rides upon the motor's cavitation plane.

Only two pieces of 4x8 ft. ¼ in. thick plywood and ordinary lumber stock are required. Framing is held to an absolute minimum with plywood skinstressed to offer greatest strength and light weight. Complete and ready to go Minimax weighs only 68 lbs. and may be handled by one man on a car-top carrier. No building form is required because the hull is developed on the plywood

as the work progresses.

Start by marking a centerline lengthwise on a 4x8 ft. sheet of ¼ in. plywood. If you are using AC grade exterior plywood, mark the C side so that it will be on the inside of the hull. Then using a yard stick with a hole in one end for a pencil, drive a nail 24 in. from the pencil hole and mark a semicircle on what will be the fore end of the plywood bottom as in Fig. 2. Also measure 30 in. from the fore end and lay out the gore or segment. Saw out the gore first, then the 24 in. semicircle.

Now, taking the other sheet of ¼ in. plywood which will be used for the deck, again lay out a centerline and 24 in. semicircle on the C side. Also lay out the cockpit opening as in Fig. 2 and the coaming, stringer and fore strut pieces on the part to be cut out for the cockpit opening. No gore or segment is cut in the deck. Saw out the deck and other pieces and fasten ¾ x 1½ in. reinforcing strips with waterproof glue and 1 in #14 galv. *Stronghold* nails to the plywood fore strut and stringer pieces as in Fig. 2.

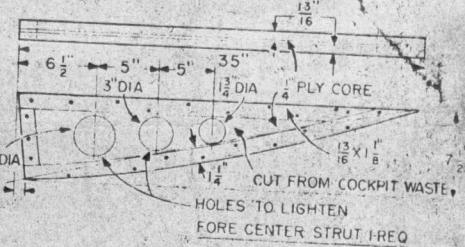
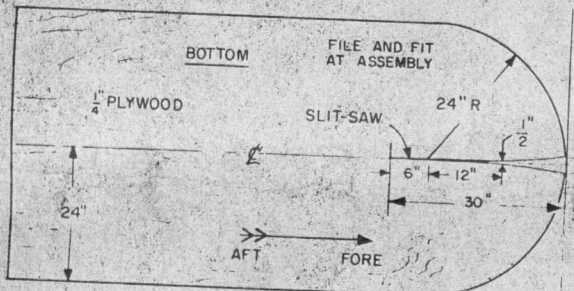
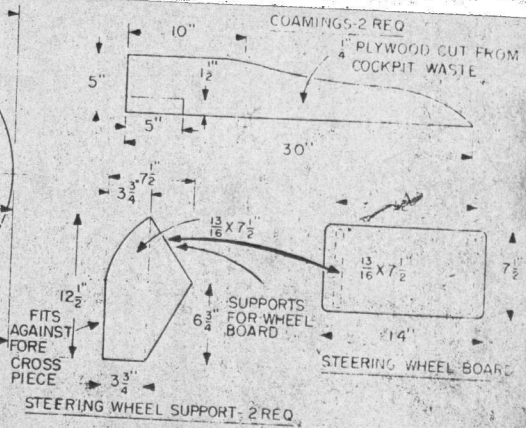
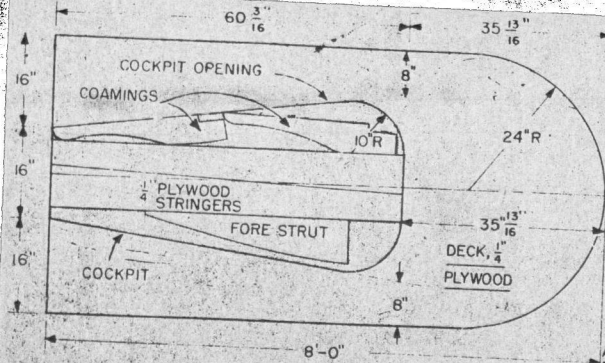

2

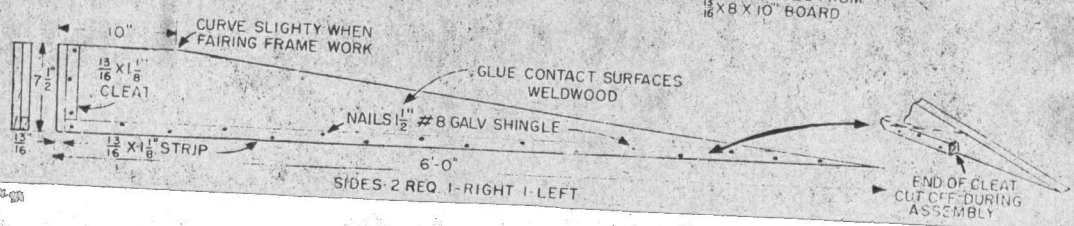
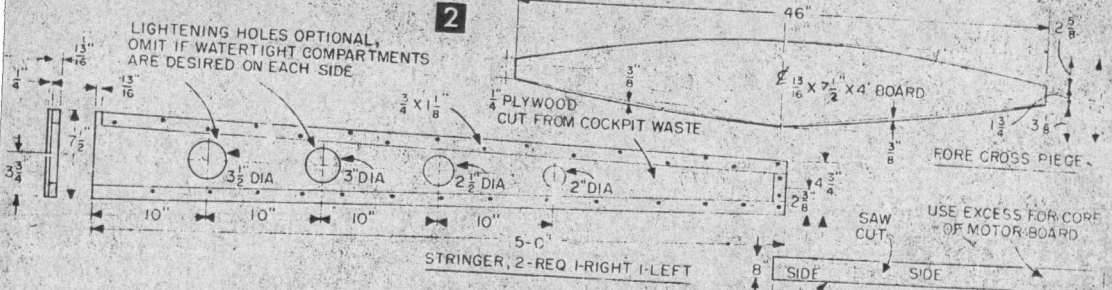

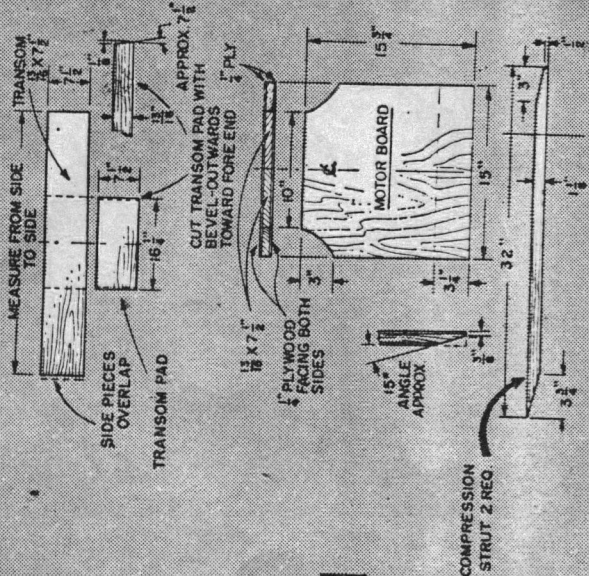
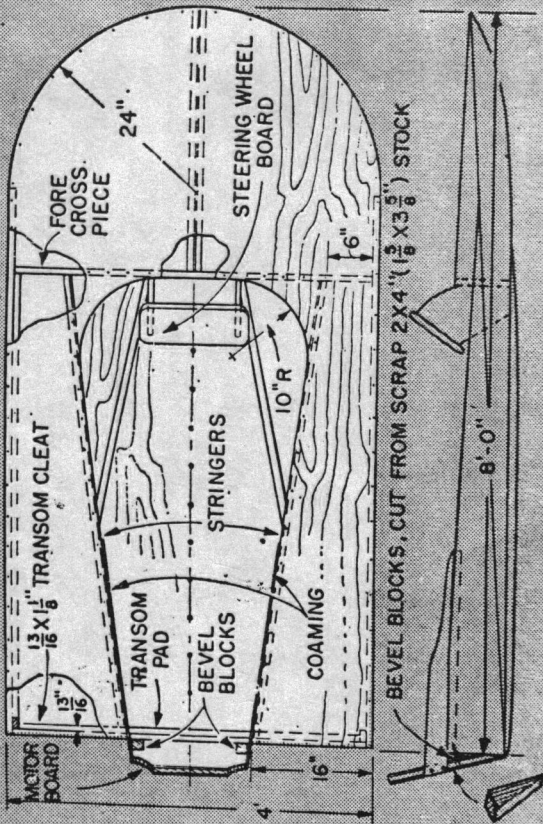

3

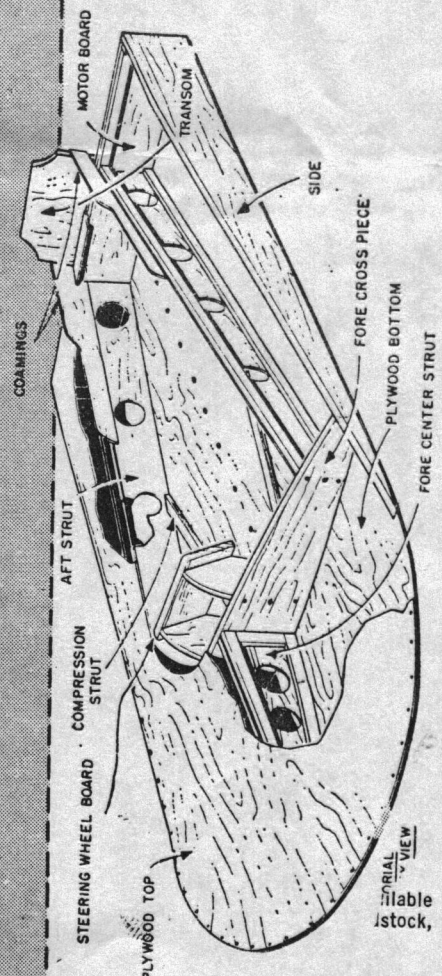

PROCEDURE

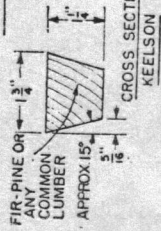

TIE BAR
STRIP OF 16 GAGE STRAP IRON TO HOLD SLIT TOGETHER WHILE HULL IS BEING SHAPED.



HOW KEELSON IS FASTENED TO PLYWOOD BOTTOM

4

ORIAL VIEW
able
istock,

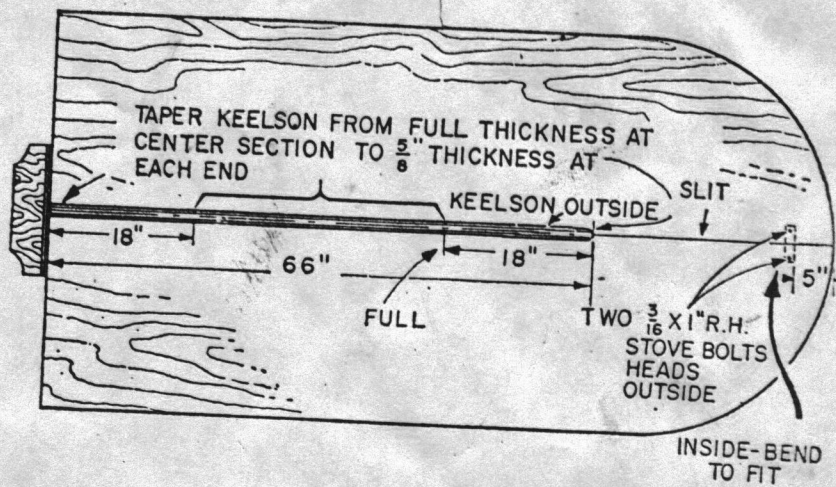

Set the pieces aside until the glue dries and cut the fore cross piece (Fig. 2). To find the location of the cross piece on the bottom, place the fore strut over the slit and gore and carefully bend up the bottom. Mark the plywood bottom at the aft end of the fore strut. Set the cross piece in position on the mark (Fig 3) and clamp in place.

To close the gore, use a bar clamp or place a loop of rope over the fore end of the bottom and twist together with a stick until the gore closes. Then make the metal tie bar (Fig. 4) and bolt to the inside of the bottom across the closed gore to hold the fore end together. With a hand plane, bevel and fit the lower edges of the fore strut to fit tightly against the bottom. Coat contacting edges of the bottom and fore strut with waterproof glue and clamp together. Fasten with # 5 x 7/8 in. *fh* screws spaced 3 in. apart and driven through from underside of the bottom on each side of gore into the strut. Remove the fore cross piece, apply glue to edges contacting bottom and fore strut and re-clamp. Fasten with # 5 x 7/8 in. *fh* screws spaced 4 in. apart across bottom and two #8 x 1 3/4 in. *fh* screws to fore strut.

Next, cut the two side pieces and fasten the strip and cleat with glue and #6 x 1 1/4 in. *fh* screws making one right and one left hand piece. When dry, set the sides on the hull bottom and fasten with glue and #5 x 7/8 in. *fh* screws spaced 4 in. apart. For the transom, measure the distance between the two sides at the stern and cut the transom from the same size stock as the sides. Assemble to the hull (Fig. 3) with glue and 7/8 in. *fh* screws spaced 3 in apart to the bottom and #8 x 1 1/2 in. *fh* screws to the side cleats. Make the transom (Fig. 3), bevel the ends and fasten to

the inside center of the transom with glue and # 6 x 1 1/4 in. *fh* screws.

Your next step is the installation of the previously made stringers. Since the sides of the stringers are to be flush with the edges of the cockpit opening on the deck, temporarily place the stringers in position in the hull and also the deck plywood. Trim and fit the fore end of the stringer to fit tightly against the fore cross piece and flush with the deck edge. Then remove the deck and stringers, coat contacting edges of stringers with glue and reinstall in the hull, fastening with 1 in. stronghold nails through the bottom and to the transom pad. Make the steering-wheel supports and pad (Fig. 2), and fasten the supports to the fore cross piece with six # 8 x 1 3/4 in. *fh* screws and the pad to the supports with six #8 x 1 3/4 in. *fh* screws. Cut the compression struts (Fig. 3) and fasten to the bottom on the inside of the hull with # 5 x 7/8 in. *fh* screws driven through the bottom from the underside. Also install 3/4 x 1 1/8 in. cleats at the bottom of the transom on each side of the compartments formed by the stringers.

Before assembling the deck to the hull (Fig. 5), apply Kuhls *Three-Way Preservative* to the inside of the watertight fore compartment and side compartments. Then coat the top edges of all parts that will come in contact with the deck with glue. Place the deck plywood in position and nail the fore curved portion of deck and bottom plywood together with 1 in. nails clinched on the bottom. Fasten the remainder of the deck to the sides, transom and stringers with #5 x 7/8 in. *fh* screws. When the glue is dry, trim the deck and bottom plywood flush.

The motor board (Fig. 3) consists of two pieces 1 x 8 in. stock, edge glued and sand-

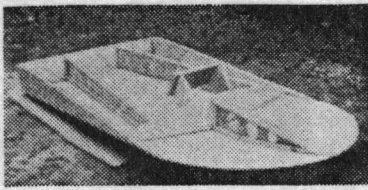

The inner compression struts and bracing members are shown here in Figure 5 and in bottom drawing far left.

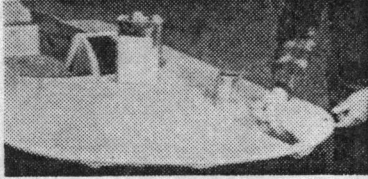

Fiberglassing adds to cost but waterproofs all seams permanently, as shown in Figure 6, left, and gives extra strength.

wicked between two layers of 1/4 in. plywood. When dry, bevel lower edge as in Fig. 3 and fasten to transom with four #10 x 2 in. fh screws. Hold a scrap piece of 2 by 4 in. stock against the transom and motor board and mark to cut two bevel blocks (Fig. 3). Install blocks with glue and two #10 x 3 in. fh screws. Fasten previously cut coamings to stringers and motor board with #5 x 7/8 fh screws as in Fig. 3. Now turn the hull over, make the keelson and fasten with glue and #7 x 1 in. fh screws spaced 5 in. apart. Use washers under screw heads and drive screws from inside of hull.

To make the hull watertight, cover all outside seams with 3 in. wide fiberglass tape and resin. First round all edges with a hand plane and sandpaper. Then dust all joints and apply one coat of fiber glass resin about 2 in. beyond the edges. Place the fiberglass tape over the seam, tacking one end to keep it in place, and apply more resin to saturate the tape. Smooth all wrinkles with the brush or your hand (Fig. 6), and allow resin to set. Follow with two coats of resin and, after resin has hardened, feather-edge tape with #80 wet or dry sandpaper. Be sure to place fiberglass over the gore and slit in the bottom. If lightening holes have been omitted in the stringers to make watertight side compartments, apply fiberglass tape to corners where stringers and cross piece join.

Regardless of the color combination you intend to paint your version of Minimax, give the outside of the hull and inside of the cockpit 2 coats of white primer paint. Sand each coat lightly after drying and follow with two coats of marine enamel.

Mount a steering wheel on the wheel board (Fig. 1), or use the board as a hand rail and steer the craft with the stick control.

STATEMENT OF USES

TYPE: A fast outboard-powered hydroplane for water sport use on protected waters.

LENGTH: 8 ft.

BEAM: 4 ft.

WEIGHT: 68 lbs.

CAPACITY: 2.

FEATURES: Convex bottom forward with high-lift after plane. Self-contained air chambers will support 900 lbs. Fiberglass tape on all seams make hull permanently watertight. One man can easily handle this boat on car-top carriers.

SPEED: 15 MPH with 3 hp outboard motor. Outboard motors up to 15 hp may be used for increased speed.

MATERIALS LIST—MINIMAX

No.	Size and Description	Use
PLYWOOD		
2	1/4"x4x8' AC grade, exterior plywood	deck and bottom
1	1/4"x15x32" AC grade, exterior plywood	motor board
LUMBER		
1	1x8"x10' spruce, hemlock or pine	sides and motor board core
1	1x8"x8' spruce, hemlock or pine	cross piece and transom
1	1x8"x8' spruce, hemlock or pine	transom pad
1	1x8"x8' spruce, hemlock or pine	steering supports
1	1x8"x8' spruce, hemlock or pine	rip saw for 1 1/8" reinforcing strips
1	1 1/4x1 3/4"x6' spruce, hemlock or pine	keelson
FASTENINGS		
1 lb or pint	Weldwood glue or Elmer's Waterproof	
3 gr	#5x7/8" fh wood screws	
4 doz	#6x1 1/4" fh wood screws	
2 doz	#7x1" fh wood screws	
3 doz	#8x1 1/2" fh wood screws	
2 doz	#8x1 3/4" fh wood screws	
4	#10x3" fh wood screws	
1 lb	1" galv. Stronghold nails (available from Herter's Inc., Waseca, Minn.)	
PAINT AND FIBERGLASS		
15 yd	3" wide fiberglass tape	
1 pt	fiberglass resin with hardener (available from The Castolite Co., Woodstock, Illinois)	
1 pt	white primer paint	
1 pt	white Boat Life enamel	
1 pt	red, green, blue as desired Boat Life enamel	

MINIMAX

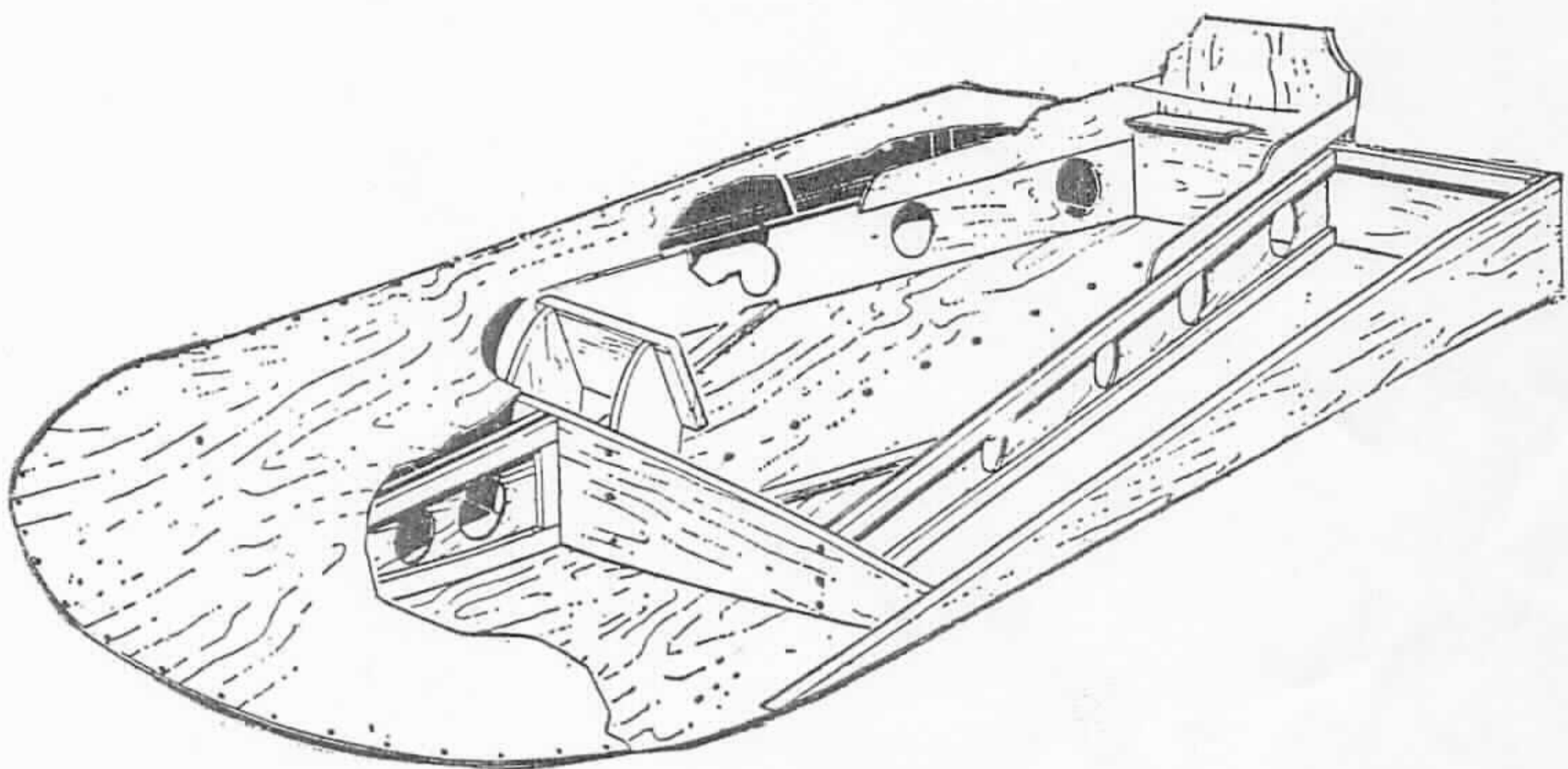

Most boat for the least money is this happy little hot rod racing dish. One weekend of work, or even one day if you're experienced, will have you ready for the water for under \$20. Clamp on a small outboard, and go....

■ Minimax is exactly what the name implies—a boat requiring the minimum in time and material to build to give you the maximum in performance and water-sport fun. Actually, Minimax was built in one day at a cost of \$20. It will carry two people, take outboard motors ranging from 3 to 15 *hp*, has a watertight air compartment that will support 900 lbs. even with the cockpit completely filled with water.

As to performance, Minimax will plane a 165 lb. man up to 15 *mph* with a 3 *hp* outboard motor. With 10 *hp* and over (Fig. 1), the hull planing area diminishes until Minimax becomes air-borne and rides upon the motor's cavitation plane.

Only two pieces of 4x8 ft. $\frac{1}{4}$ in. thick plywood and ordinary lumber stock are required. Framing is held to an absolute minimum with plywood skinstressed to offer greatest strength and light weight. Complete and ready to go Minimax weighs only 68 lbs. and may be handled by one man on a car-top carrier. No building form is required because the hull is developed on the plywood

as the work progresses.

Start by marking a centerline lengthwise on a 4x8 ft. sheet of $\frac{1}{4}$ in. plywood. If you are using AC grade exterior plywood, mark the C side so that it will be on the inside of the hull. Then using a yard stick with a hole in one end for a pencil, drive a nail 24 in. from the pencil hole and mark a semicircle on what will be the fore end of the plywood bottom as in Fig. 2. Also measure 30 in. from the fore end and lay out the gore or segment. Saw out the gore first, then the 24 in. semicircle.

Now, taking the other sheet of $\frac{1}{4}$ in. plywood which will be used for the deck, again lay out a centerline and 24 in. semicircle on the C side. Also lay out the cockpit opening as in Fig. 2 and the coaming, stringer and fore strut pieces on the part to be cut out for the cockpit opening. No gore or segment is cut in the deck. Saw out the deck and other pieces and fasten $\frac{3}{4}$ x $1\frac{1}{8}$ in. reinforcing strips with waterproof glue and 1 in #14 galv. *Stronghold* nails to the plywood fore strut and stringer pieces as in Fig. 2.

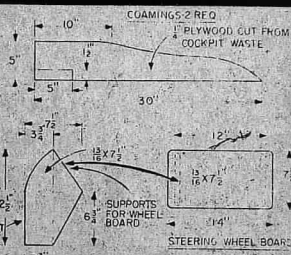
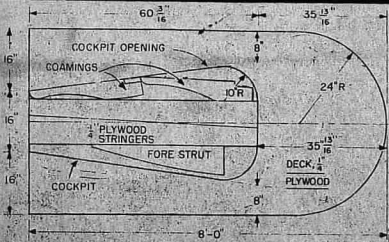

STEERING WHEEL SUPPORT-2 REQ.

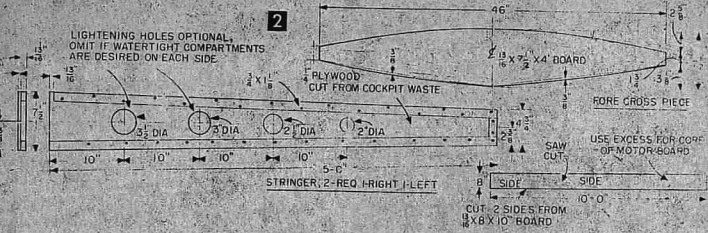
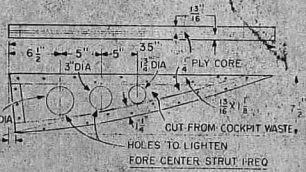
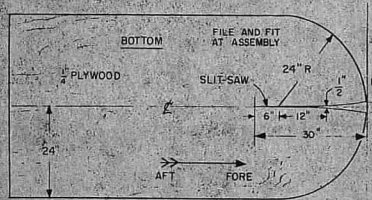

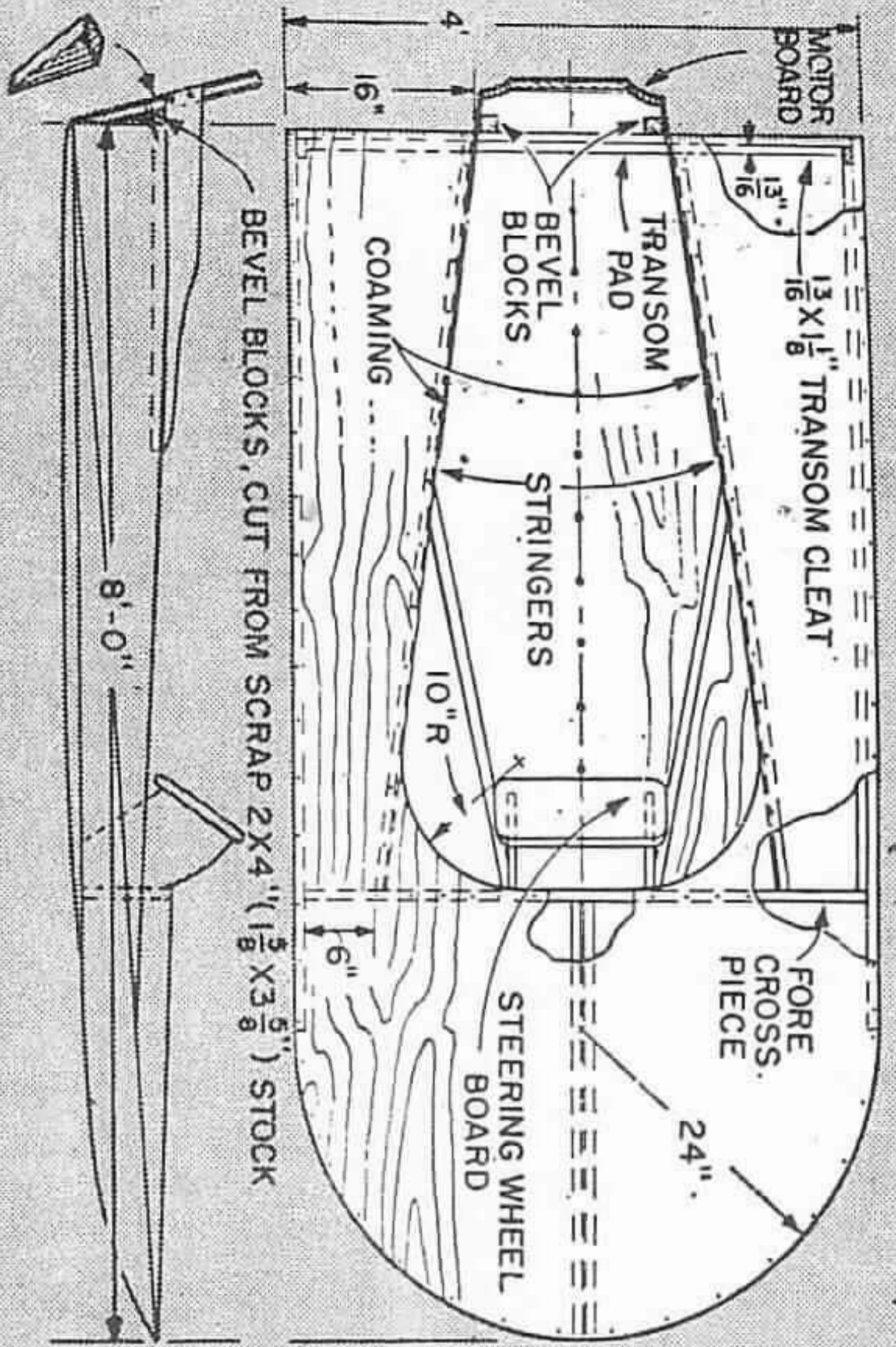

3

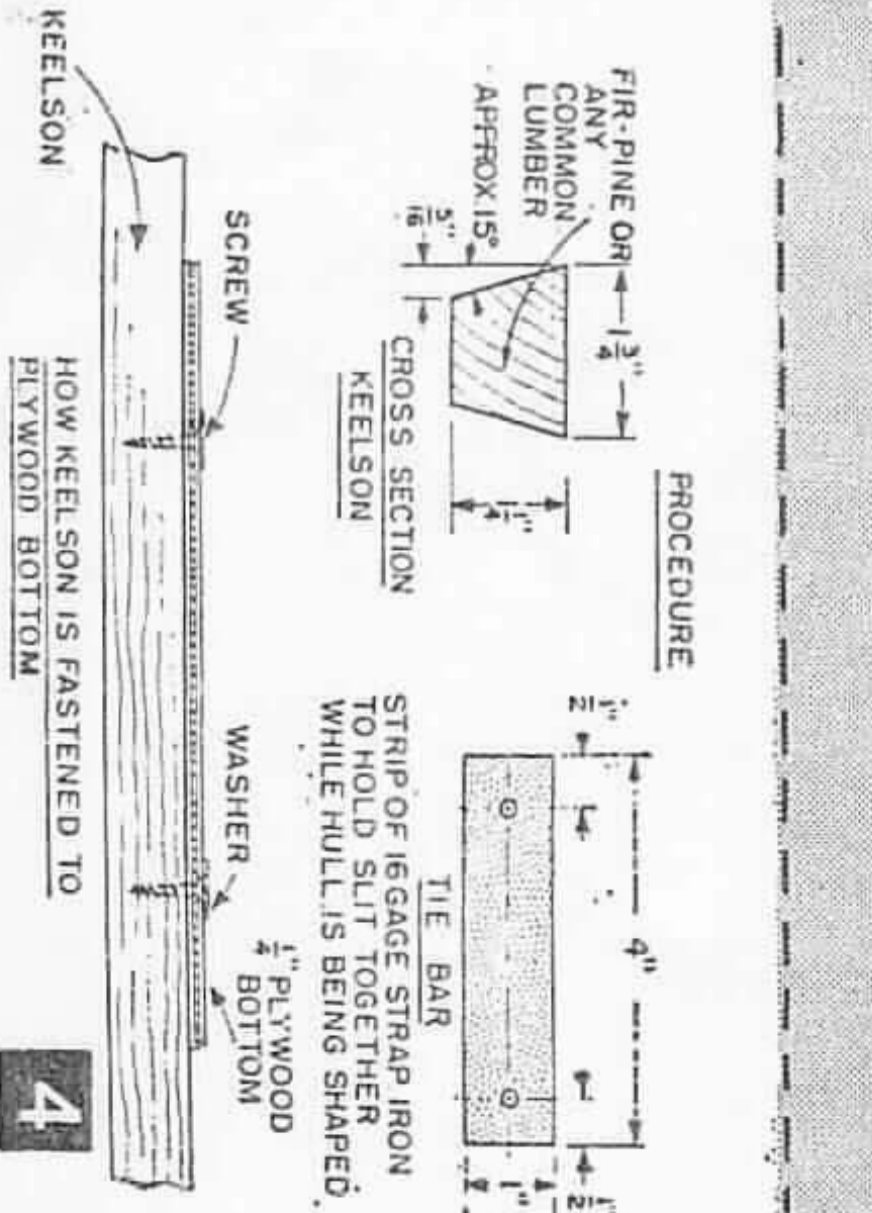
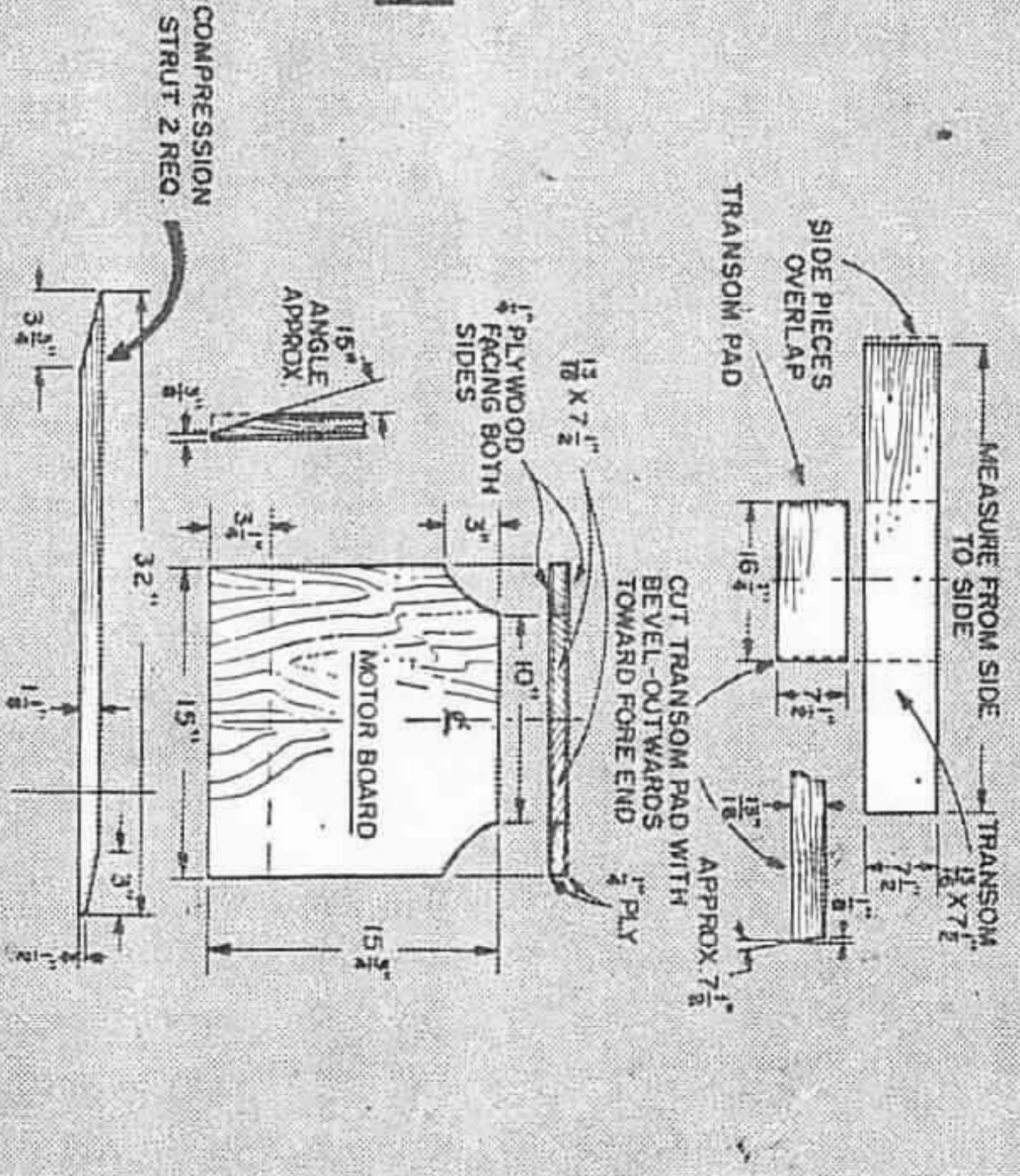
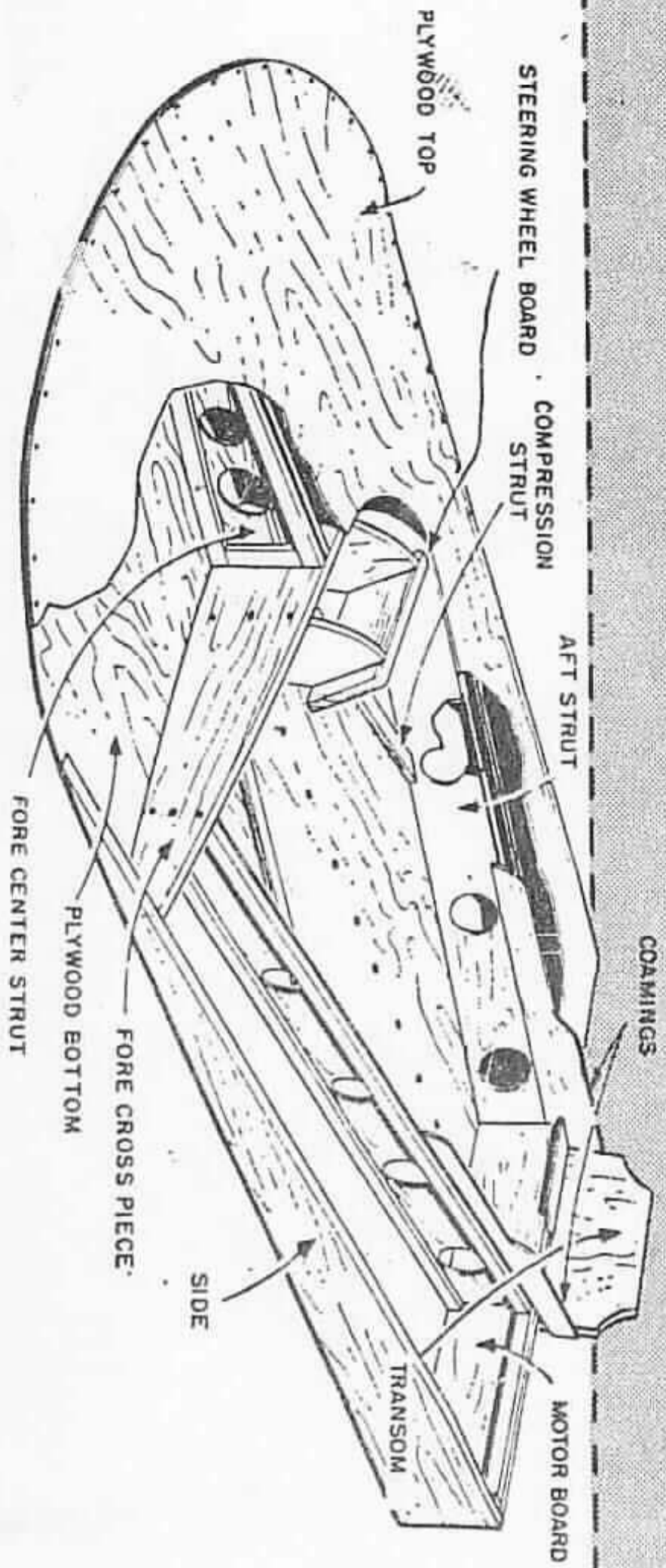

4

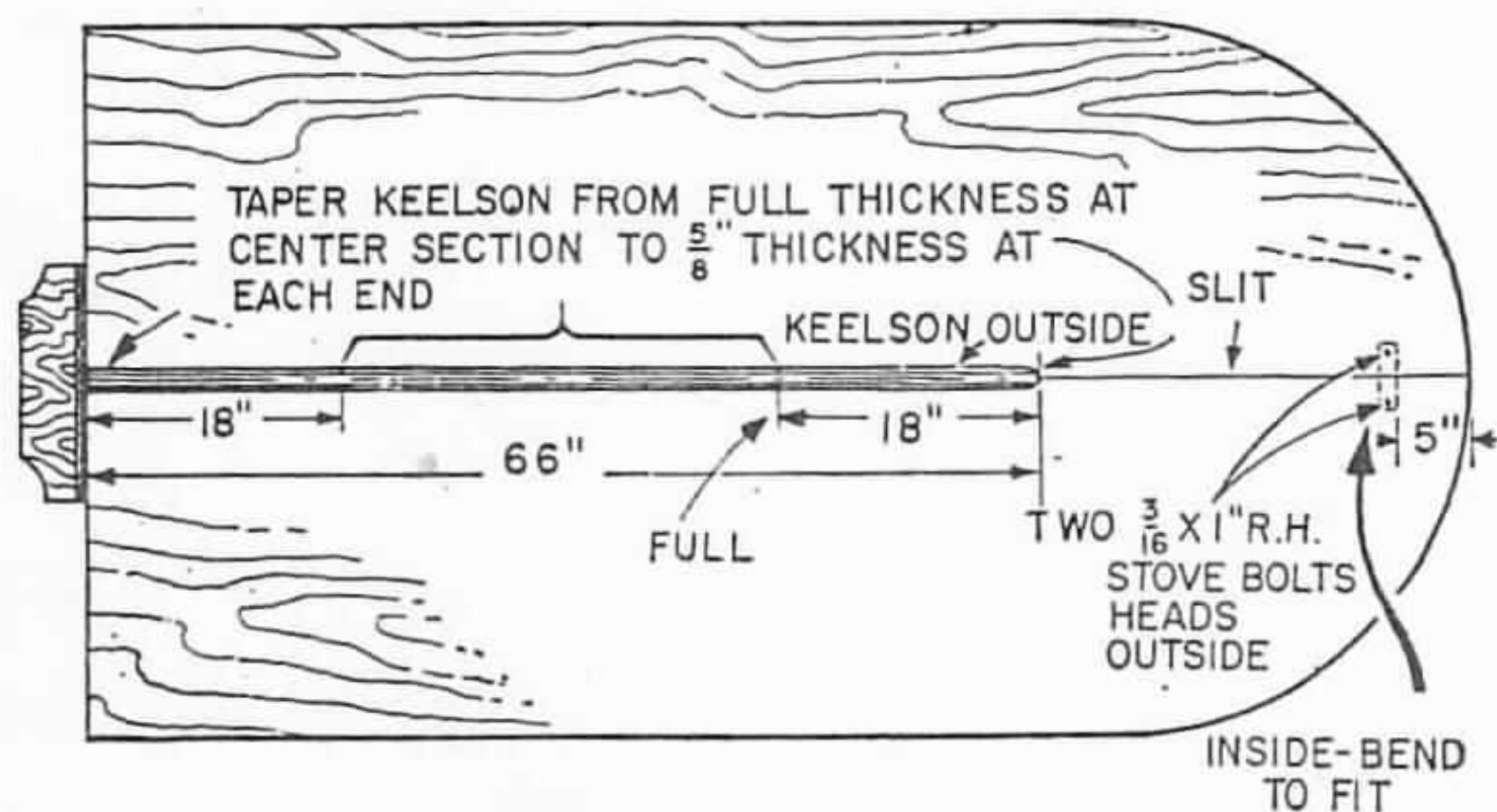

Set the pieces aside until the glue dries and cut the fore cross piece (Fig. 2). To find the location of the cross piece on the bottom, place the fore strut over the slit and gore and carefully bend up the bottom. Mark the plywood bottom at the aft end of the fore strut. Set the cross piece in position on the mark (Fig. 3) and clamp in place.

To close the gore, use a bar clamp or place a loop of rope over the fore end of the bottom and twist together with a stick until the gore closes. Then make the metal tie bar (Fig. 4) and bolt to the inside of the bottom across the closed gore to hold the fore end together. With a hand plane, bevel and fit the lower edges of the fore strut to fit tightly against the bottom. Coat contacting edges of the bottom and fore strut with waterproof glue and clamp together. Fasten with # 5 x 7/8 in. *fh* screws spaced 3 in. apart and driven through from underside of the bottom on each side of gore into the strut. Remove the fore cross piece, apply glue to edges contacting bottom and fore strut and re-clamp. Fasten with # 5 x 7/8 in. *fh* screws spaced 4 in. apart across bottom and two # 8 x 1 3/4 in. *fh* screws to fore strut.

Next, cut the two side pieces and fasten the strip and cleat with glue and # 6 x 1 1/4 in. *fh* screws making one right and one left hand piece. When dry, set the sides on the hull bottom and fasten with glue and # 5 x 7/8 in. *fh* screws spaced 4 in. apart. For the transom, measure the distance between the two sides at the stern and cut the transom from the same size stock as the sides. Assemble to the hull (Fig. 3) with glue and # 5 x 7/8 in. *fh* screws spaced 3 in. apart to the bottom and # 8 x 1 1/2 in. *fh* screws to the side cleats. Make the transom (Fig. 3), bevel the ends and fasten to

the inside center of the transom with glue and # 6 x 1 1/4 in. *fh* screws.

Your next step is the installation of the previously made stringers. Since the sides of the stringers are to be flush with the edges of the cockpit opening on the deck, temporarily place the stringers in position in the hull and also the deck plywood. Trim and fit the fore end of the stringer to fit tightly against the fore cross piece and flush with the deck edge. Then remove the deck and stringers, coat contacting edges of stringers with glue and reinstall in the hull, fastening with 1 in. stronghold nails through the bottom and to the transom pad. Make the steering-wheel supports and pad (Fig. 2), and fasten the supports to the fore cross piece with six # 8 x 1 3/4 in. *fh* screws and the pad to the supports with six # 8 x 1 3/4 in. *fh* screws. Cut the compression struts (Fig. 3) and fasten to the bottom on the inside of the hull with # 5 x 7/8 in. *fh* screws driven through the bottom from the underside. Also install 3/4 x 1 1/8 in. cleats at the bottom of the transom on each side of the compartments formed by the stringers.

Before assembling the deck to the hull (Fig. 5), apply Kuhls *Three-Way Preservative* to the inside of the watertight fore compartment and side compartments. Then coat the top edges of all parts that will come in contact with the deck with glue. Place the deck plywood in position and nail the fore curved portion of deck and bottom plywood together with 1 in. nails clinched on the bottom. Fasten the remainder of the deck to the sides, transom and stringers with # 5 x 7/8 in. *fh* screws. When the glue is dry, trim the deck and bottom plywood flush.

The motor board (Fig. 3) consists of two pieces 1 x 8 in. stock, edge glued and sand-

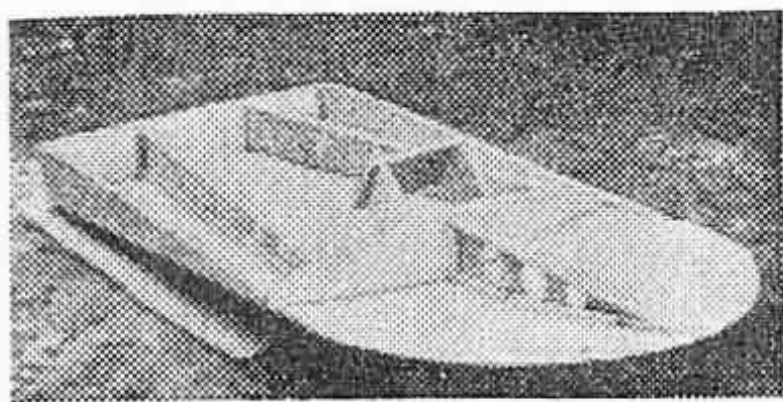

The inner compression struts and bracing members are shown here in Figure 5 and in bottom drawing far left.

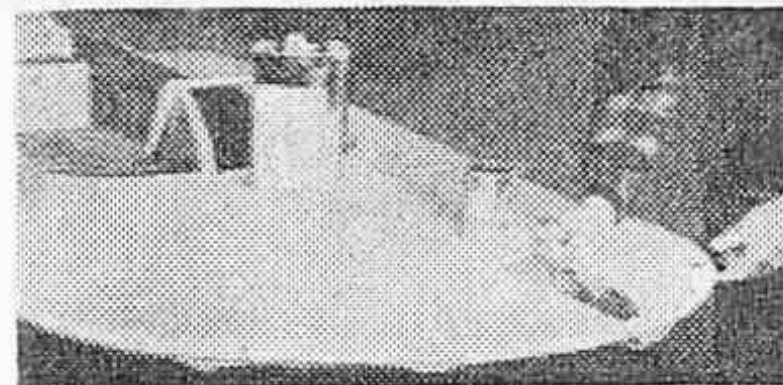

Fiberglassing adds to cost but waterproofs all seams permanently, as shown in Figure 6, left, and gives extra strength.

wicked between two layers of $\frac{1}{4}$ in. plywood. When dry, bevel lower edge as in Fig. 3 and fasten to transom with four #10 x 2 in. *fh* screws. Hold a scrap piece of 2 by 4 in. stock against the transom and motor board and mark to cut two bevel blocks (Fig. 3). Install blocks with glue and two #10 x 3 in. *fh* screws. Fasten previously cut coamings to stringers and motor board with #5 x $\frac{7}{8}$ *fh* screws as in Fig. 3. Now turn the hull over, make the keelson and fasten with glue and #7 x 1 in. *fh* screws spaced 5 in. apart. Use washers under screw heads and drive screws from inside of hull.

To make the hull watertight, cover all outside seams with 3 in. wide fiberglass tape and resin. First round all edges with a hand plane and sandpaper. Then dust all joints and apply one coat of fiber glass resin about 2 in. beyond the edges. Place the fiberglass tape over the seam, tacking one end to keep it in place, and apply more resin to saturate the tape. Smooth all wrinkles with the brush or your hand (Fig. 6), and allow resin to set. Follow with two coats of resin and, after resin has hardened, feather-edge tape with #80 wet or dry sandpaper. Be sure to place fiberglass over the gore and slit in the bottom. If lightening holes have been omitted in the stringers to make watertight side compartments, apply fiberglass tape to corners where stringers and cross piece join.

Regardless of the color combination you intend to paint your version of Minimax, give the outside of the hull and inside of the cockpit 2 coats of white primer paint. Sand each coat lightly after drying and follow with two coats of marine enamel.

Mount a steering wheel on the wheel board (Fig. 1), or use the board as a hand rail and steer the craft with the stick control.

STATEMENT OF USES

TYPE: A fast outboard-powered hydroplane for water sport use on protected waters.

LENGTH: 8 ft.

BEAM: 4 ft.

WEIGHT: 68 lbs.

CAPACITY: 2.

FEATURES: Convex bottom forward with high-lift after plane. Self-contained air chambers will support 900 lbs. Fiberglass tape on all seams make hull permanently watertight. One man can easily handle this boat on car-top carriers.

SPEED: 15 MPH with 3 *hp* outboard motor. Outboard motors up to 15 *hp* may be used for increased speed.

MATERIALS LIST—MINIMAX

No.	Size and Description	Use
PLYWOOD		
2	$\frac{1}{4}$ "x4x8' AC grade, exterior plywood	deck and bottom
1	$\frac{1}{4}$ "x15x32" AC grade, exterior plywood	motor board
LUMBER		
1	1x8"x10' spruce, hemlock or pine	sides and motor board core
1	1x8"x8' spruce, hemlock or pine	cross piece and transom
1	1x8"x8' spruce, hemlock or pine	transom pad
1	1x8"x8' spruce, hemlock or pine	steering supports
1	1x8"x8' spruce, hemlock or pine	rip saw for $1\frac{1}{8}$ " reinforcing strips
1	$1\frac{1}{4}$ x1 $\frac{3}{4}$ "x6' spruce, hemlock or pine	keelson
FASTENINGS		
1 lb or pint	Weldwood glue or Elmer's Waterproof	
3 gr	#5x $\frac{7}{8}$ " <i>fh</i> wood screws	
4 doz	#6x1 $\frac{1}{4}$ " <i>fh</i> wood screws	
2 doz	#7x1" <i>fh</i> wood screws	
3 doz	#8x1 $\frac{1}{2}$ " <i>fh</i> wood screws	
2 doz	#8x1 $\frac{3}{4}$ " <i>fh</i> wood screws	
4	#10x3" <i>fh</i> wood screws	
1 lb	1" galv. Stronghold nails (available from Herter's Inc., Waseca, Minn.)	
PAINT AND FIBERGLASS		
15 yd	3" wide fiberglass tape	
1 pt	fiberglass resin with hardener (available from The Castolite Co., Woodstock, Illinois)	
1 pt	white primer paint	
1 pt	white Boat Life enamel	
1 pt	red, green, blue as desired Boat Life enamel	

