

Section II Cabin Cruisers



1 The sweeping lines of the Sea Hawk conceal plenty of space for sleeping a large family.

STATEMENT OF USES

USES: Cabin cruiser for overnight trips on protected waters or general water sports use on rivers and small lakes. May also be used for deep-sea fishing on ocean waters during favorable weather conditions.

DESIGN: Convex bottom, sports-type cabin cruiser with hi-lift bottom.

CONSTRUCTION: $\frac{3}{8}$ in. plywood over a developed surface, wooden framework and trussed bottom members.

LENGTH: 21 ft. 2 in. (at waterline 16 ft. 9 in.)

BEAM: 8 ft. (actually measures a fraction less than 8 ft., making it legal to transport on highways via trailer.) Beam at waterline 6 ft. 10 in.

HEIGHT: 57 in. at bow; 6 ft. 7 in. from keel planking to cabin top; 36 in. at transom.

SLEEPING CAPACITY: 2 adults and 1 or 2 children in forward cabin, and 2 to 3 adults on cots in open cockpit.

DRAFT: 4 in. with motor tilted up.

WEIGHT: 975 lbs. less motor.

SPEED: With 1957 Mercury Mark 75, 60 HP. outboard motor at #1 tilt hole, Sea Hawk planes a pay load of over $\frac{1}{2}$ ton (7 adults) at $\frac{7}{8}$ throttle at a speed of 23 m.p.h. With two people aboard speed varied between 28 to 32 m.p.h.

PROPELLER: Use Mercury's #48-26506AI two blade, 13 in. pitch, bronze wheel for speeds of 24 to 32 m.p.h. with gross loads up to 1 ton. If maximum performance with two persons aboard is wanted, (gross load not to exceed 1600 lbs.) use 15 in. pitch #48-26505AI wheel.

GAS CONSUMPTION: By running the big Merc at $\frac{2}{3}$ to $\frac{3}{4}$ throttle we consistently averaged just under 8 miles per gallon at speeds of 24 m.p.h.

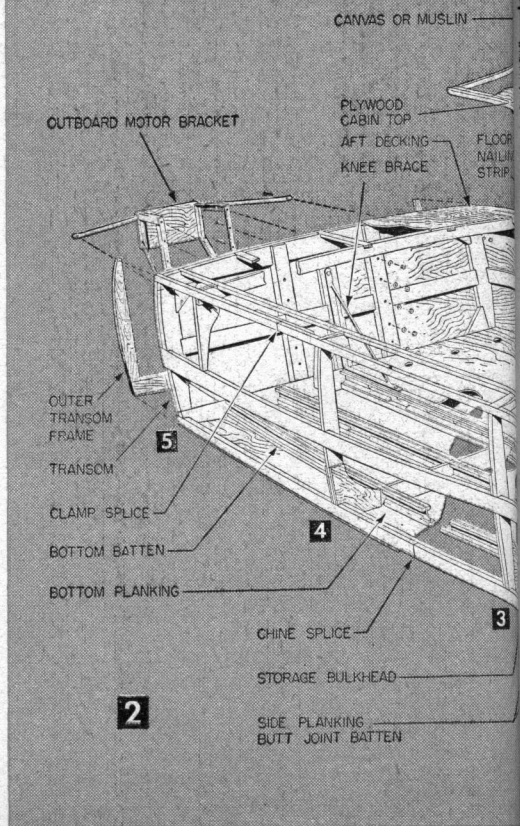

Sea Hawk a 21-ft. Outboard Cabin Cruiser

By WILLIAM D. JACKSON
Naval Architect

If you're looking for a good, big, roomy cabin cruiser for over night trips on protected waters or day time deep sea fishing, *Sea Hawk* is the boat for you. And, you'll save about \$1000 by building it yourself.

Sea Hawk's forward cabin has bunk space for 2 adults and 2 children. Cots placed in the open cockpit will provide sleeping accommodations for another 3 adults. The two compartments just aft of the seats and under the cockpit cabin (Fig. 2), house the galley stove and equipment. Steering wheel and outboard-motor controls are located at the skipper's seat on the left or port side of the cockpit cabin. For design and performance data, see Statement of Uses.

Sea Hawk is a big boat and unless you have a garage about 25 ft. long it will have to be built outside. However, the frames, transom and stem can be made up indoors. The bow assembly can

also be temporarily fitted together indoors, then disassembled and erected outside when weather permits.

Study the Materials List first. You will note that most of the lumber and plywood can be purchased at your local lumber yards. Do not substitute oak for the framework with other kinds of wood. If you cannot obtain oak locally, it can be ordered from Maurice G. Condon Co., Inc., 270 Ferris Avenue, White Plains, New York. Regarding glues, use *Elmers Waterproof* for oak or other woods being joined to oak. *Weldwood* may be used for all wood other than oak. Three coats of *Kuhls Three-Way Preservative* applied to framework and plywood is suggested to stop and prevent mold and fungus, the progenitors of rotted hulls.

Start building *Sea Hawk* by drawing the frames (Fig. 3) full size on building paper. To

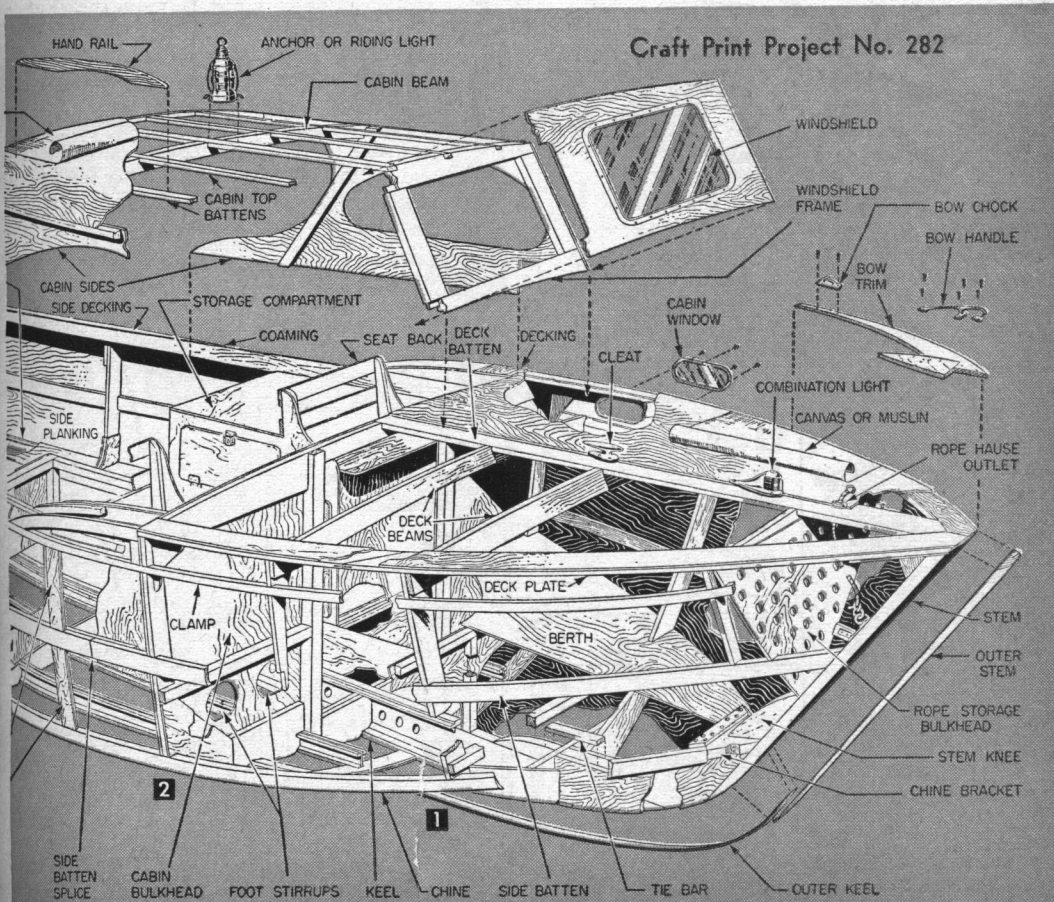

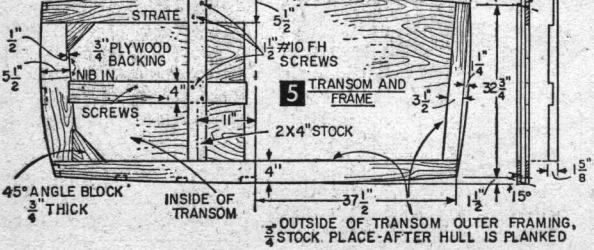
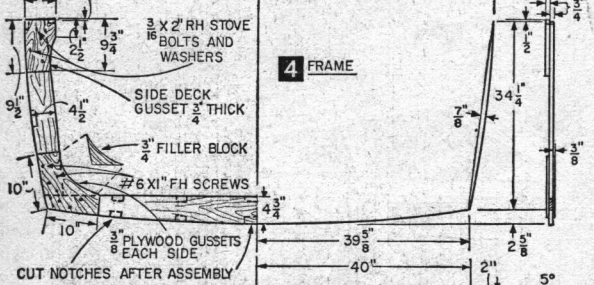
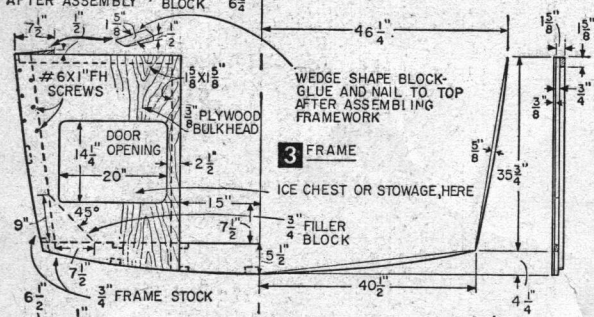
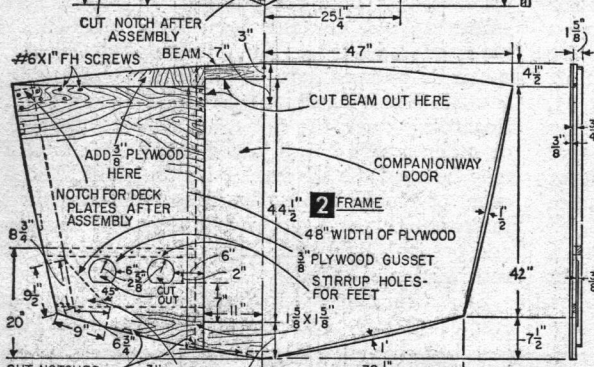
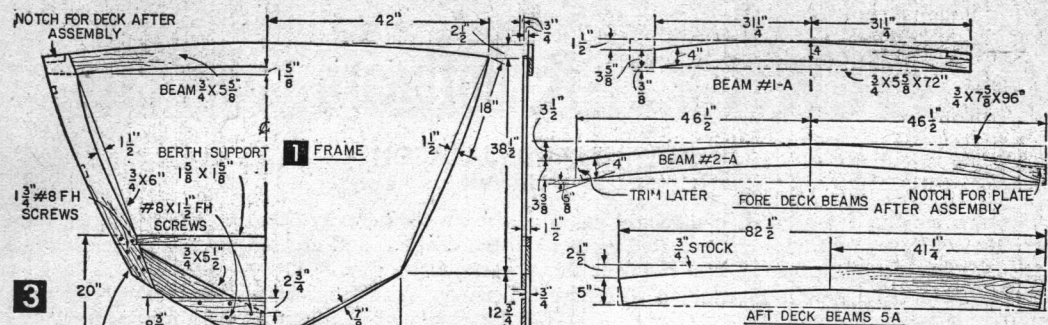

draw the deck beam curves and convex bottom and side frame member so they are fair and even, regardless of length or height, mark the amount of curve at the exact center of the beam with a pencil. Then, with the paper over a sheet of plywood, partially drive finishing nails at the ends of the curve to be drawn. Place two 1/2 x 1/4-in. wooden strips on the paper so that they touch the finishing nails and overlap at the center pencil mark. Fasten the overlapping ends together with nails. Now, holding a pencil against the strips from one finishing nail to the other and the pencil will scribe a perfect arc of a circle.

Frame #5, the transom, may be drawn directly on a sheet of 3/4-in. plywood. An inch has been added to the 32 3/4-in. dimension to allow for bevels on the top and bottom edges. After cutting the plywood to shape, lay out and cut the fram-

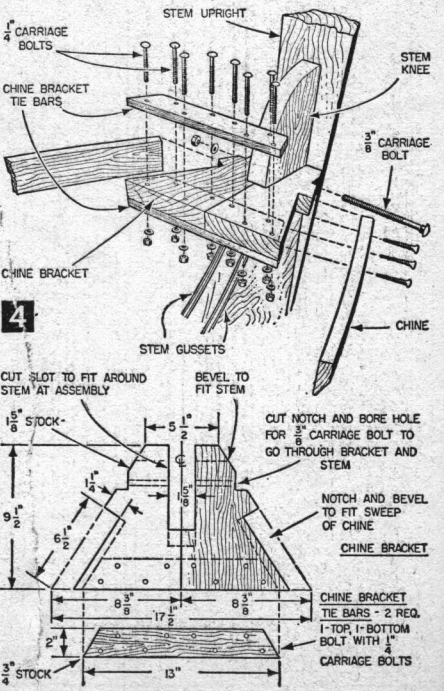

MATERIALS LIST—SEA HAWK

No. Req.	Size and Description	Use
PLYWOOD		
2 pc.	3/8" x 4' x 12' ext. fir AA 5-ply	bottom
1 pc.	3/8" x 4' x 8' ext. fir AA 3-ply	bottom
2 pc.	3/8" x 4' x 12' ext. fir AA 5-ply	sides
2 pc.	3/8" x 4' x 10' ext. fir AA 5-ply	sides
2 pc.	3/8" x 4' x 10' ext. fir AA 3-ply	forward, side and aft decking
2 pc.	3/8" x 4' x 8' ext. fir AC 3-ply	bulkheads
2 pc.	3/8" x 4' x 8' ext. fir AA 3-ply	cabin top
2 pc.	3/8" x 4' x 8' ext. fir AC 3-ply	floor
1 pc.	3/8" x 30" x 48" ext. fir AC 3-ply	floor
2 pc.	3/8" x 4' x 8' ext. fir AC 3-ply	berths and cabinet fronts
2 pc.	1/4" x 4' x 8' ext. fir AC 3-ply	cabinets or seats
1 pc.	3/8" x 4' x 8' 3-ply	transom and stem
4 pc.	3/8" x 30" x 7' 5-ply ext. African Mahogany (Harbor Sales Corp., Baltimore, Md.)	cabin sides, windshield, trim, cabin door and dash.

LUMBER

1 pc.	1 1/4" x 5 1/2" x 14' oak or fir	keel
1 pc.	1 5/8" x 5 5/8" x 16' keel upright	
1 pc.	3/4" x 1 1/2" x 12' oak or fir	outer keel
1 pc.	3/4" x 3 1/2" x 7' oak or fir	outer keel
2 pc.	1 1/4" x 2 1/2" x 14' oak	chines
2 pc.	1 1/4" x 2 1/2" x 10' oak	chines
2 pc.	3/4" x 5 5/8" x 6' fir	curved sheer clamps
2 pc.	3/4" x 1 1/4" x 16' fir	sheer clamps
2 pc.	3/4" x 1 1/4" x 5' fir	sheer clamps
2 pc.	3/4" x 1 1 3/8" x 8' fir	deck plates
2 pc.	3/4" x 5 5/8" x 11' fir	side battens
4 pc.	3/4" x 1 3/4" x 12' fir	bottom battens
1 pc.	3/4" x 3 5/8" x 14' fir	floor beam
2 pc.	3/4" x 5 5/8" x 12' fir	floor longrons
1 pc.	3/4" x 7 5/8" x 12' fir	and fillets
2 pc.	3/4" x 5 5/8" x 11' mahogany	coamings
1 pc.	3/4" x 5 5/8" x 12' fir	carlins
2 pc.	3/4" x 2" x 20' fir	moldings
1 pc.	1 1/4" x 5 1/2" x 8' fir	spray rails
1 pc.	3/4" x 5 5/8" x 10' fir	deck batten
1 pc.	1 5/8" x 9 5/8" x 5' fir	stem upright
1 pc.	1 5/8" x 11 5/8" x 4' fir	stem knee
1 pc.	1 5/8" x 7 5/8" x 6' fir	lower stem
1 pc.	1 5/8" x 7 5/8" x 6' fir	outer stem
1 pc.	3/4" x 7 5/8" x 16' fir	2A and 5A deck beams
1 pc.	3/4" x 5 5/8" x 6' fir	1A deck beam
1 pc.	1-1 1/4" x 11 5/8" x 8' fir	windshield
1 pc.	1 1/4" x 3 5/8" x 8' fir	windshield
1 pc.	1 1/4" x 3 5/8" x 6' fir	cabin uprights
1 pc.	1 1/4" x 9 5/8" x 8' fir	cabin upright beam
4 pc.	3/4" x 1 1/4" x 6' fir	cabin top battens
1 pc.	3/4" x 1 1/2" x 6' fir	cabin-top batten
1 pc.	1 1/4" x 7 1/2" x 8' fir	cabin-top beam
2 pc.	1 1/4" x 1 1/4" x 6' fir	cabin top molding
4 pc.	1 5/8" x 1 5/8" x 12' fir	cabinet framing
2 pc.	3/4" x 1 1/2" x 10' fir	and berth supports
2 pc.	3/4" x 7 5/8" x 10' mahogany	deck trim board
1 pc.	3/4" x 9 5/8" x 10' oak	frames
2 pc.	3/4" x 7 5/8" x 10' oak	frames
4 pc.	3/4" x 5 5/8" x 16' oak	frames
1 pc.	3/4" x 5 5/8" x 12' oak	frames

2 pc.	3/16" x 2" x 2" x 8' angle iron	
2 pc.	3/16" x 1 1/4" x 1 1/4" x 3' angle iron	
10	3/8" x 3" bolts	
6	3/8" x 2 1/4" bolts	
2	5/16" x 2" bolts	
2	5/16" x 1" bolts	
1 pc.	3/4" x 12" x 48" ext. fir plywood	
1 pc.	1/4" x 12" x 24" ext. fir plywood	
FASTENINGS		
TRANSOM KNEE		
1 pc.	1/4" x 1 1/2" x 38" strap iron	
1 pc.	3/4" black iron pipe 28" long	
3	3/4" x 2" carriage bolts	
1	3/8" x 6" carriage bolt	
2	5/16" x 3" lag screws	
OUTBOARD BRACKET		
1 qt.	Kuhls Bedlast	
2 gals.	Kuhls Three Way Preservative	
1 gal.	Kuhls Canvas Cement	
1 gal.	Kuhls Brushlast	
1 gal.	Firzite	
3 pts.	Condon's Boat life enamel for bottom	
2 qts.	Condon's Boat list enamel for sides	
1 1/2 gals.	Paint for inside of hull	
1 qt.	Condon's Boatlife Plasticlear for Cabin sides	
PAINT		
FITTINGS		
2	16" x 32" aluminum trailer windows with screws #1731	
1	14" x 20" aluminum trailer window with screws #125185	
(The above listed windows may be purchased from Woodlin Mfg. Co., Marshall, Michigan)		
2	4" x 8" port lights	
(Available from Aluminum Marine Co., Auburn, N. Y.)		
1	standard 8 lb. Danforth anchor	
1	storm 13 lb. Danforth anchor	
100 ft.	1/2" manila rope for anchor line	
1	moorring ring	4 4" straight chocks
3	6" cleats	1 bow handle
1	combination light	rope end and deck pipe
1	360° white riding light	
6	12 ft. lengths of 3/4" aluminum molding	
1 gross	#6 x 1" oval-head Monel screws for bottom	
FIBER GLASS		
12 yds.	50" width, heavy duty weight fiber glass cloth	
7 gals.	Resinote (with catalyst and accelerator) (The above available from Herter's Inc., Waseca, Minnesota.)	

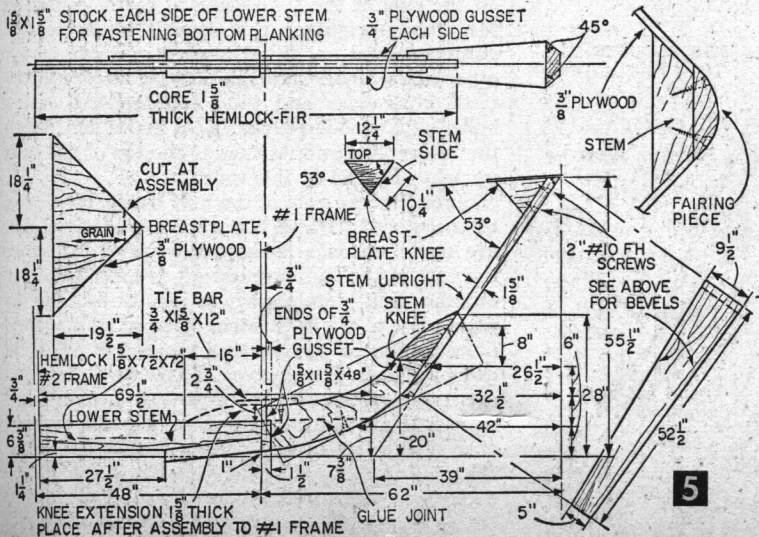

ing pieces that go on the inside of the transom and fasten to the plywood with glue and #8 x 1 1/2-in. fh screws spaced 3 in. apart and staggered. Note that two 2 x 4-in. pieces are also fastened to the inside surface of the transom to provide support for the outboard bracket. The outside framing is added after the hull is planked.

After drawing the full-size patterns for frames #1 to #4 do not cut them out as they will be used for assembly purposes. Transfer

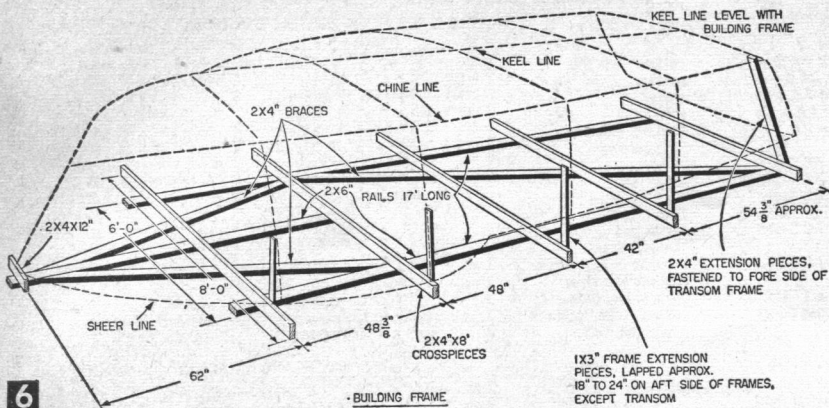

the outlines of the various frame pieces with carbon paper, a pointed transfer wheel, similar to a dressmaker's wheel, or by using a sharp awl and marking a series of holes through the paper onto the $\frac{3}{4}$ -in. frame stock, and plywood for bulkheads. Saw the pieces to shape on a bandsaw and place them in their respective places on the

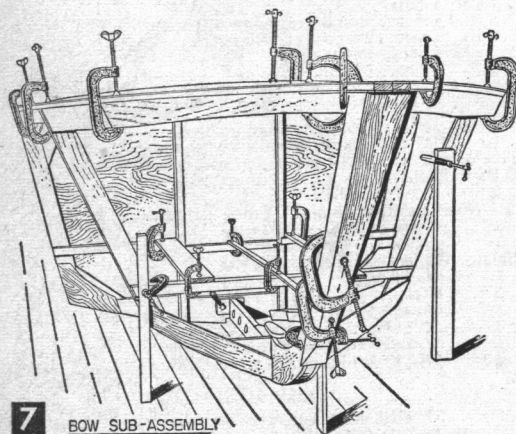

BOW SUB-ASSEMBLY

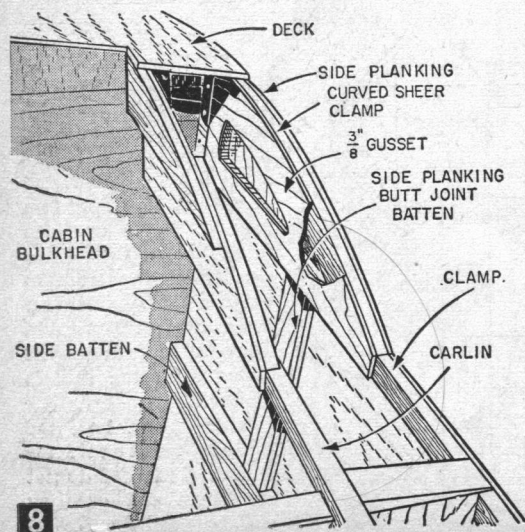

paper patterns to assure perfect alignment. Fasten with glue and screws or bolts as noted in Fig. 3. Be sure to assemble the frames on a flat surface, because once the glue has dried the shape is locked in, warped or otherwise.

Make the stem assembly next. Oak is not recom-

mended for the stem, instead use clear hemlock as a first choice and fir as a second. Do not use any of the pines as they are too soft and will not hold fastenings. First make a full-size drawing of the stem parts (Fig. 5) on paper as you did for the frames. Transfer the shapes of the parts, including the two $\frac{3}{4}$ -in. plywood gussets, to the stem stock. The stem upright can be drawn directly on the wood from which it is to be cut. Saw the parts to shape and bevel the stem upright 45° on each side as in Fig. 5. The curve at the lower end of the stem upright can best be cut and shaped after assembly to the stem knee.

When assembling the stem, first fasten the lower stem to the stem knee with glue and two #10 x 2 $\frac{1}{2}$ -in. *fh* screws countersunk $\frac{3}{4}$ in. Leave clamps on until glue dries. Then fasten the $\frac{3}{4}$ -in. plywood gussets to each side of the joint between the lower stem and knee with glue and #8 x 1 $\frac{1}{2}$ -in. *fh* screws. Be sure to measure and mark the lower stem for the location of the end of the gussets which must be $1\frac{1}{2}$ in. forward of the 62 in. dimension in Fig. 5.

Finally, fasten the stem upright to the stem knee with glue and two #10 x 2-in. *fh* screws countersunk so that the curve can be cut without striking the screw heads. Clamp a straightedge on the side of the stem knee to aid in centering the stem upright so that it will be in correct alignment and not tilted toward one side or the other of the lower stem and knee. Clamp together until glue dries and plug counterbored screw holes with wooden plugs. Also make and fasten the breastplate and its knee to the top of the stem upright (Fig. 5.) at this time.

Since the fore part of the hull frame, consisting of the stem, #1 and 2 frames and deck plates, are made up as a subassembly (Fig. 7) before the rest of the hull framework is assembled, lay out the deck plate shown in Fig. 10 full size on paper. Use a $\frac{1}{2}$ x $\frac{3}{4}$ -in. strip of wood bent against nails driven at the various measured points to draw the deck plate curves. Since two deck plates are required, transfer the drawings to two pieces of $\frac{3}{4}$ x 11 $\frac{5}{8}$ x 96-in. stock as in Fig. 10, making each deck plate of two pieces joined with a $\frac{1}{4}$ x 1 $\frac{1}{4}$ x 14-in. plywood spline glued in place. Cover each deck plate with $\frac{1}{4}$ -in. plywood glued and

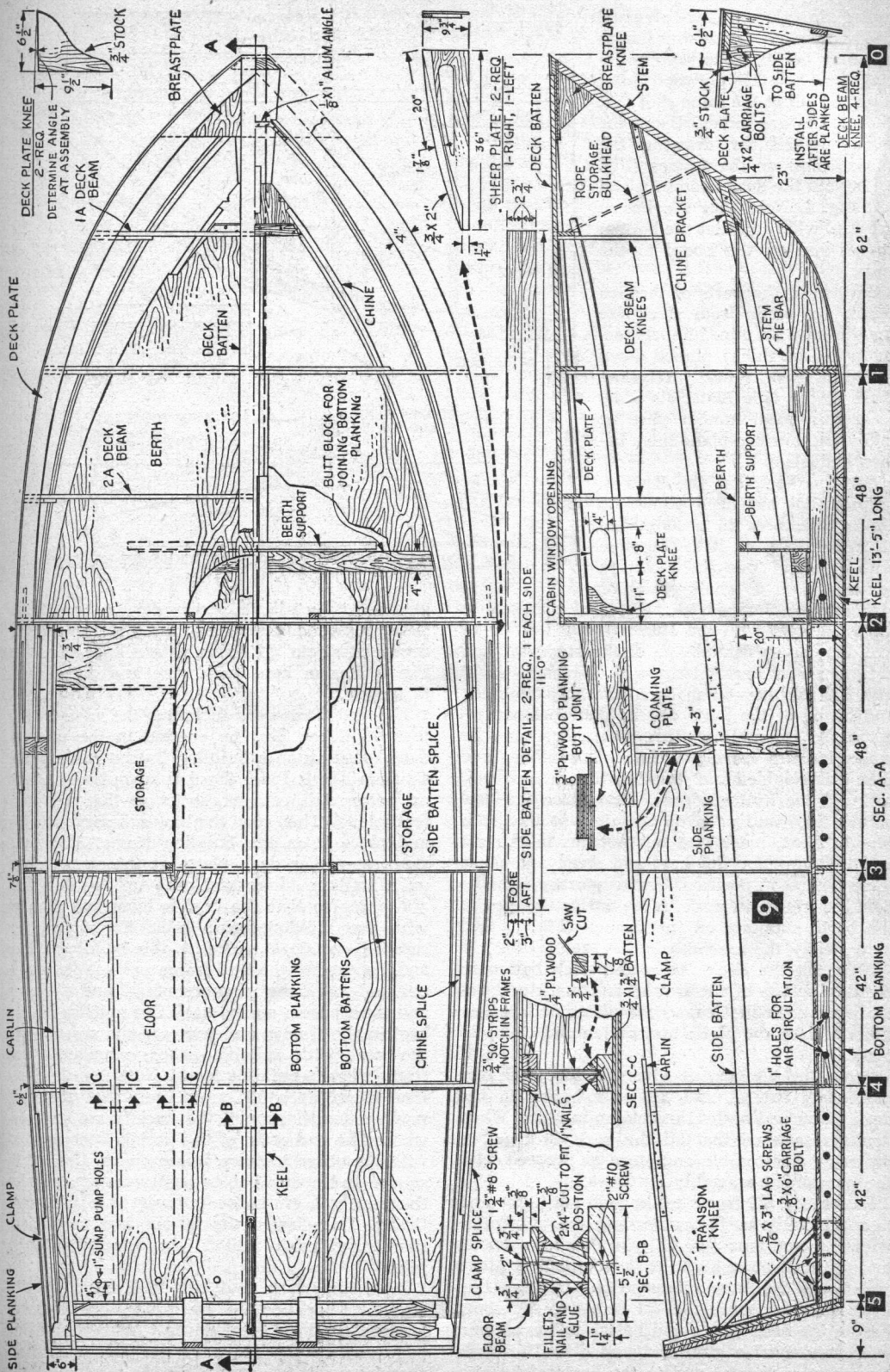

DECK PLATE

CLAMP

SIDE PLANKING

DECK PLATE KNEE
2-REQ.
DETERMINE ANGLE
AT ASSEMBLY
1A DECK BEAM
6 1/2"
9 1/2"
3/4" STOCK

BREASTPLATE

DECK BATTEN

2A DECK BEAM

BERTH

STORAGE

FLOOR

KEEL

1" X 1" ALUM. ANGLE

CHINE

BUTT BLOCK FOR JOINING BOTTOM PLANKING

SIDE BATTEN SPLICE

BOTTOM PLANKING

BOTTOM BATTENS

CHINE SPLICE

36"
1 1/8"
20"
3/4" X 2"
1 1/2"

DECK BATTEN

2-REQ. 1-RIGHT, 1-LEFT

11'-0"

11'-0"

2"
3"
2"
11" PLYWOOD NOTCH IN FRAMES

CLAMP SPLICE

FLOOR BEAM

3/4" X 3/8" SCREW

24" - CUT TO FIT POSITION

2" #10 SCREW

5"
1 1/2"

ROPE STORAGE BULKHEAD

DECK BEAM KNEES

CHINE BRACKET

DECK PLATE

CABIN WINDOW OPENING

3" PLYWOOD PLANKING BUTT JOINT

COAMING PLATE

SIDE PLANKING

SAW CUT

1" PLYWOOD

3/4" X 1 1/2" BATTEN

CLAMP

TRANSOM KNEE

1/2" X 3" LAG SCREWS

3/8" X 6" CARRIAGE BOLT

BREASTPLATE KNEE

STEM

DECK BEAM KNEES

BERTH SUPPORT

48"

48"

42"

42"

42"

42"

42"

42"

42"

6 1/2"
3" STOCK

DECK PLATE

23"

STEM TIE BAR

62"

48"

48"

42"

42"

42"

42"

42"

42"

3" X 2" CARRIAGE BOLTS TO SIDE

INSTALL AFTER SIDES ARE PLANKED

DECK BEAM KNEE, 4-REQ.

48"

48"

48"

42"

42"

42"

42"

42"

42"

42"

0

1

2

3

4

5

KEEL 13'-5" LONG

SEC. A-A

BOTTOM PLANKING

1" HOLES FOR AIR CIRCULATION

9

nailed in place. This plywood need not be one continuous length but may be joined to save material, just so the plywood joint does not fall at the same spot that deck plates are joined. Using the same method for drawing the curved lines on the frames (Fig. 4), lay out the deck beams 1A and 2A, Fig. 3. Note that the beams are 4 in. wide and that the bottom curves run off the board at the ends.

Several of the parts of the Sea Hawk are made from stock-size 2 x 4-in. and 2 x 6-in. lumber (actually 1½-in. thick) planed down to 1¼-in. thick. When purchasing these pieces (see Materials List) have your local lumber yard or mill works surface-plane them before delivery.

For the keel, cut the 2 x 6-in. lumber that has been planed to 1¼-in. thickness to a length of 13 ft. 5 in. Fasten it to the stem with glue and four #10 x 2-in. *fh* screws. Use a chalk line or straightedge clamped to the side of the stem to align the keel with the stem.

A temporary assemblage of the stem, #1 and 2 frames and deck plates with C-clamps as in Fig. 7 should now be made so that any trimming and fitting of the parts can be done before permanently assembling. This assemblage can be made indoors during inclement weather, and then disassembled and stored until you are ready to build the hull outdoors. First place the keel on the floor and prop up the stem so that it is plumb. Next, mark and cut notches in the #1 and 2 frames for the keel and stem, and place these frames in position. Use temporary props to hold the frames in place. A few strips clamped to the berth supports on the frames (Fig. 7) will help steady the assembly.

Now, set the deck plates and deck batten in position on top of the frames and mark and cut the notches in the frames for plates and batten. Then replace the plates and batten and clamp in place.

From the dimensions given in Fig. 9 fit the previously cut 1A and 2A deck beams to the deck plates and batten, and clamp in place. When you are satisfied that all the parts fit together properly, disassemble and store or proceed with the permanent assembly outdoors.

Fasten the #2 frame to the keel with glue and two #10 x 2½-in. *fh* screws and the #1 frame with glue and four #10 x 2½-in. *fh* screws driven into the stem at an angle as for toe-nailing. Make and fasten the knee extension and tie bar (Fig. 9) to further secure the #1 frame to the stem. Fasten the deck plates and batten to frames and deck beams with glue and two #8 x 1¼-in. *fh* screws at each joint and to the breastplate with

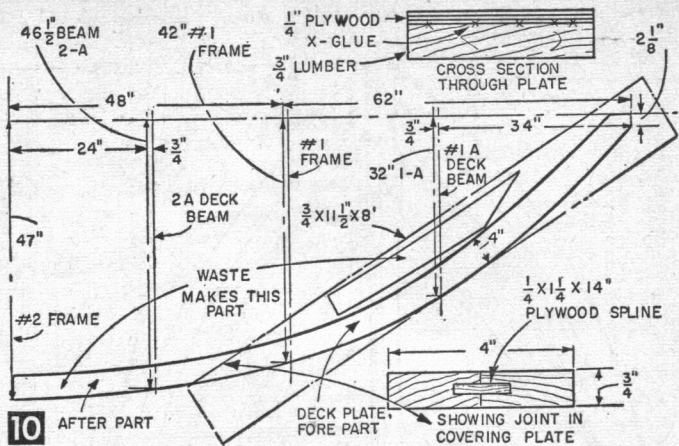

10 AFTER PART

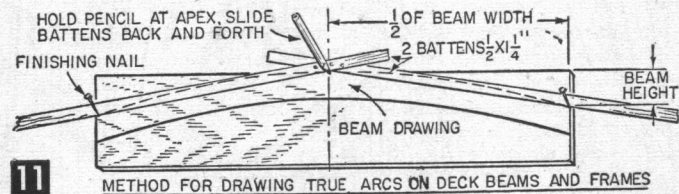

11

glue and #8 x 1-in. *fh* screws driven through the ¾-in. plywood. Reinforce the joint where the deck plates join #2 frame with a knee shown in Fig. 9. Fasten knee with glue and #8 x 1¼-in. *fh* screws.

The hull framework including the subassembly just built, can best be erected in the up-side-down position on a building fixture made of 2 x 4's as in Fig. 6. Place the fixture on house bricks or, better still, cement blocks, so that it is perfectly level. Then turn the bow subassembly over and place it on the building frame. Allow the stem, or rather deck plates at the stem to rest on a 2 x 4 in. block and prop up the keel and #2 frame so that the keel is level and parallel with the building-frame rails. For props, use scrap ¾-in. stock nailed to the building frame and clamped to the hull frame parts. Now, measure and mark the locations of #3 and 4 frames and the transom on the keel. Cut notches for the keel in the frames and transom and assemble to the keel with suitable props extending from frame sides to building frame. Note that the transom is set at a 15° angle and that the keel notch extends through the keel frame and plywood. The end grain of the keel is later covered with the outer transom frame pieces. Use a 2 ft. square and plumb bob to set frames square with the keel both crosswise (athwart ship) and vertically. Then fasten the frames and transom to the keel with two #10 x 2½-in. *fh* screws at each joint.

It is important that the keel be absolutely straight. Check for high or low spots by sighting lengthwise along the keel or placing a straightedge on it. Raise or lower the frames on their props if needed to straighten the keel.

Installation of chines is your next job. Since it is impossible to obtain chine stock long enough to reach from transom to stem, join 14 and 5½ ft. length with a reinforcing strip of chine stock about 40 in. long between #3 and 4 frames as in Figs. 2 and 9. Fasten with Elmers waterproof glue and #10 x 2½-in. fh screws spaced 6 in. apart and staggered to prevent splitting. To mark the frames and transom for chine notches, saw off a 2 or 3 in. length of chine stock, hold in place on the frame and mark around with a pencil. Then cut the notches slightly undersize with a hand saw. When the chines are clamped in position, run your hand saw between the chines and frames cutting the frames at a slight angle to make perfect contact between chines and frames.

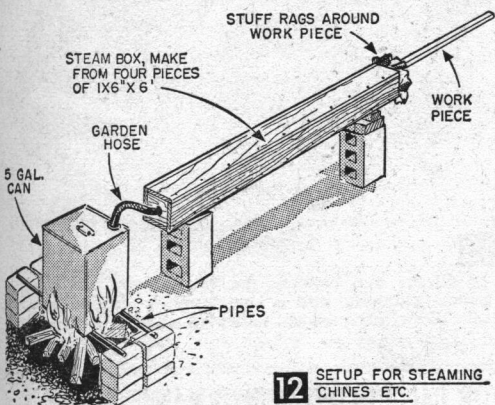

12 SETUP FOR STEAMING CHINES ETC.

Since it would be almost impossible to fasten the chine bracket to the bow at the correct angle without having the chines in place to use as a guide, make up the chine bracket (Fig. 4) at this time and hand-fit it to the stem knee. Locate it about 23 in. above the keel and bend the chines around to the bracket for alignment. Mark and fasten to the stem knee with a ¾-in. bolt.

Starting at the transom, install both chines at the same time fastening to each frame alternately to avoid pulling the framework out of alignment. Use glue and one #10 x 2½ in. fh screw at each frame and three screws at the stem knee. If chines do not bend readily at fore end, wrap with rags and soak with boiling water.

Unless you can purchase a 19 ft. length of ¾ x 1¼ for the sheer clamp, join two lengths of stock between #4 frame and the transom with a reinforcing strip as in Fig. 9. Cut notches for sheer clamps in the transom and #3 and 4 frames first then clamp the sheer clamps to the transom and frames, and bend around to the #1A deck beam. Mark for notches to be cut in #1 and 2 frames and #1A deck beam. Install the sheer clamps with one #8 x 1¾-in. fh screw at each joint.

To make the curved rise in the sheer line just aft of #2 frame, lay out and saw the curved sheer clamp and ¾-in. plywood gusset (Fig. 9)

to shape. The cutout in the gusset will prevent accumulation of moisture between side planking and this gusset which would result in premature rot. Install curved sheer clamps and gussets with five #6 x 1-in. fh screws (Fig. 8).

Side battens are next. Rip these from two 11-ft. lengths of ¾ x 5½-in. stock, tapering as in Fig. 9. Join the pieces end to end with a ¾ x 2¾-in. batten as you did the chines and clamps. To locate where to cut the notches, clamp the battens to the frames equidistant between chines and clamps and leave the forward end sweep upward toward the stem beyond #1 frame. Mark and cut the notches and fasten the side battens with one #10 x 1¾-in. fh screw at each joint. Fasten the forward ends to the stem with aluminum brackets.

Now, make up four ¾ x 1¼-in. bottom battens 12 ft. long. Dado saw a ¼-in. groove ¼-in. deep lengthwise in the center of a 1¼ in. side for plywood webs (Sec. C-C Fig. 9) to be added later. Clamp the battens to the frames and transom bottoms between keel and chines as in (Fig. 9). Then mark frames and transom for notches, remove battens and cut notches ¾ in. deep.

When assembling the battens, be sure to place grooved side toward inside of hull. Fasten with two #8 x 1½-in. fh screws at each joint. Cover the exposed ends of the chines, clamps and battens at the transom with the three outer transom frame pieces (Fig. 3). Fasten frame pieces to transom plywood with glue and #8 x 1¼-in. fh screws, spacing them about 4 in. apart and staggering.

Fairing the entire framework so that the plywood planking will make contact with the frame members is your next step. For years a jack plane, jointer plane and wood rasp have been the principal tools used for trimming and fairing a wooden boat framework. Recently, however, two new tools placed on the market have speeded up this operation. They are Stanley's *Surform* file and rasp plane and the *Perma-Grit* file put out by Skil Saw.

A ½-in. square batten about 16 ft. long to lay across the framework is also needed. Bending the batten to conform to the shape of the framework and sighting under the batten will reveal how much you will have to bevel the frames, chines etc.

Applying Planking. Starting with the bottom planking, place a 4 x 12-ft. sheet of ¾-in. plywood on the framework bottom so that a 4-ft. edge is flush with the transom and a 12-ft. edge on the center of the keel. Clamp the plywood in place and mark along the outer edges of the chine. Then remove the plywood and saw to marked shape. Fit this cut out piece of planking by placing it on the framework bottom on the opposite side of the keel. If it fits well on this side, use it as a pattern to mark the plywood for the other bottom planking side. If it does not fit, mark the other side as you did the first.

Now, place both planks in position on the

framework and clamp down. To locate fastening screw locations, crawl under the framework and pencil mark the plywood on each side of the frames and battens. Remove the planks and drill $\frac{1}{8}$ -in. holes through the plywood at center between penciled lines at each end. Connect drilled holes with light pencil lines on outside of planking for bottom frame members and two lines $\frac{3}{8}$ -in. on each side of center hole for bottom battens so that screws will not break through into $\frac{1}{4} \times \frac{1}{4}$ -in. groove cut in center of bottom battens.

At this time you should decide if you are going to cover the hull with fiber glass. Because fiber glass will not adhere if Kuhl's *Bedlast* is used between planking and framework along chines and transom, glue must be used. On the other hand if you are *not* going to fiber glass the hull, then *Bedlast* should be used along chines and transom and glue elsewhere. After applying glue to frame bottom members and keel, and glue or *Bedlast* to chines and transom, place plywood in position and clamp down. Fasten plywood planking with #8 x $1\frac{1}{4}$ -in. *fh* screws spaced 3 in. apart, stagger screws driven into bottom battens to miss groove and along chines and transom to avoid splitting.

To obtain a pattern with which to cut the triangular shaped pieces of plywood needed to plank the forward bottom of the hull, place a piece of heavy brown paper over the framework

at the bow and crease it along the edges of the framing with your fingers. Since the center edges of these forward pieces of planking cannot be brought together edge-to-edge, leave a space between as in Fig. 13 to be filled in later. Remove and cut the paper to shape, transfer outline to $\frac{3}{8}$ -in. plywood and saw to shape. Since the fore

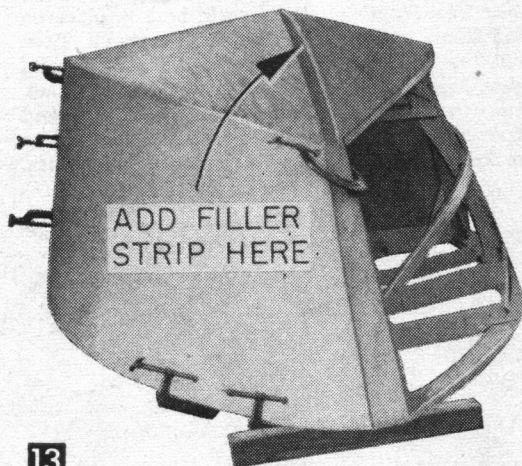

13

To fill the gap between the two forward sheets of bottom planking, add a long tapering strip of $\frac{1}{4}$ -in. plywood as indicated above.

1958 OUTBOARD MOTOR CALCULATED PERFORMANCE DATA TWO-CYCLE MOTORS

	HP @ RPM	HP @ RPM	NO. CYL.	BORE, INCHES	STROKE, INCHES	PISTON DISPLACEMENT, Cu. In.	HP @ CU. IN.	DISPLACEMENT CU. IN. PER MINUTE	PISTON TRAVEL FT. PER MIN.	WEIGHT LB.	HP/LB.
Mercury MK-78	70@5400*	.01295*	6	2.5625	2.125	66	1.06	356,400*	1910*	180	2.57
Mercury MK-75	60@5400*	.01111*	6	2.4375	2.125	60	1	324,000*	1910*	152	2.53
Flying Scott	60@4800	.01250	3	3.125	2.75	63.27	.95	303,696	2200	180	2.67
Evinrude V-4	50@4000	.01250	4	3.0	2.5	70.7	.71	282,800	1666	205	4.1
Johnson V-4	50@4000	.01250	4	3.0	2.5	70.7	.71	282,800	1666	205	4.1
Mercury MK-58	45@5400*	.00833*	4	2.5625	2.125	44	1	238,000*	1910*	122	2.71
Mercury MK-55	40@5400*	.00742*	4	2.4375	2.125	40	1	216,000*	1910*	111	2.3
Scott-Atwater	40@4800	.00833	2	3.125	2.75	42	.95	202,464	2200	142	3.55
Firestone	38@4800	.00791	2	3.0625	2.75	40.5	.936	194,448	2200	117	3.08
Buccaneer	35@4500	.00777	2	3.0625	2.75	40.5	.86	182,250	2060	134	3.83
Evinrude	35@4500	.00777	2	3.0625	2.75	40.5	.86	182,250	2060	138	3.94
Johnson	35@4500	.00777	2	3.0625	2.75	40.5	.86	182,250	2060	138	3.94
Oliver	35@4500	.00777	2	3.0625	2.875	42	.83	189,000	2160	125	3.57
Sea King "35"	35@4500	.00777	2	3.125	2.75	42	.833	189,000	2060	134	3.83
Wizard	35@4500	.00777	2	3.0625	2.875	42.35	.828	190,000	2160	125	3.57
Mercury MK-30	30@5400*	.00506*	4	2.1093	2.125	30	1	162,000*	1910*	110	3.67
Buccaneer	25@4000	.00625	2	2.875	2.75	35.7	.7	142,800	1832	130	5.2
Mercury MK-28	22@5400*	.00407*	2	2.5625	2.125	22	1	118,800*	1910*	79	3.59
Scott-Atwater-22	22@4800	.00458	2	2.8875	2.4375	27.65	.795	132,720	1950	119	5.4
Mercury MK-25	20@5400*	.00370*	2	2.4375	2.125	20	1	108,000*	1910*	75	3.75
Evinrude	18@4500	.00400	2	2.5	2.25	22	.818	99,000	1683	77	4.23
Johnson	18@4500	.00400	2	2.5	2.25	22	.818	99,000	1683	77	4.23

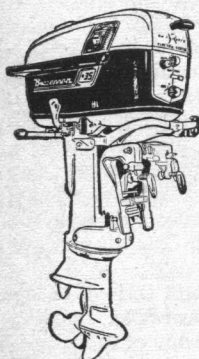

BUCCANEER 35 HP

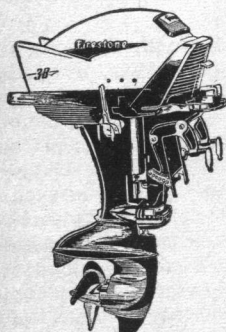

FIRESTONE 38 HP

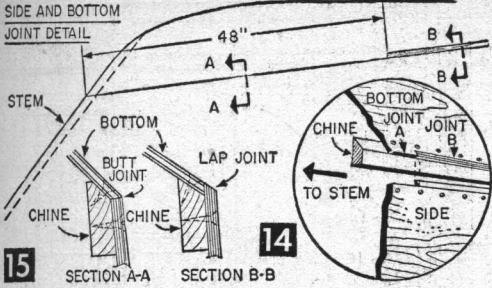

screws spaced 4 in. apart. Now glue coat the keel, chine, #1 frame and butt block for the watersoaked triangular pieces of planking, and fasten in place with #8 x 1 1/4-in. fh screws spaced 3 in. apart. Then reinforce the butt blocks by gluing the other two strips of 4 in. wide 3/8-in. plywood on top of the strips you have installed. Fasten with #8 x 1-in. fh screws spaced 2 in. apart. After the glue dries, plane the edges of the planking flush with the chine to within 48 in. of the bow (Fig. 13) and work toward the

bending and clamping a 4 x 12 ft. sheet of 3/8-in. plywood to the fore end of the framework. Pencil mark along the chine, sheer and bow, then remove and saw to shape. Plane the forward 48 in. along the chine edge at an angle so it will

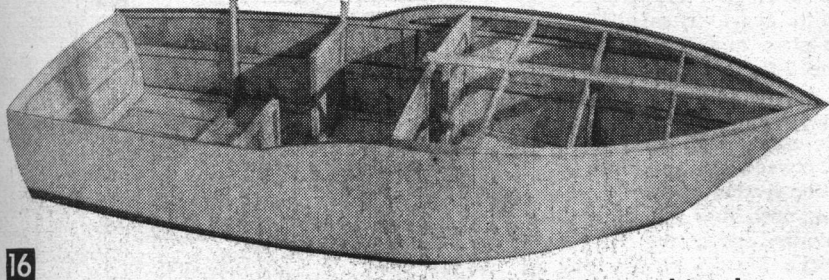

View of hull shortly after it was taken off of building frame and turned right-side up. Frames, bulkhead and deck beams retain hull shape.

48 in. of the bottom planking is butt joined to the side planking (Fig. 15) rather than lapped as it is along the rest of the chine, check to see that the sawed edge will fall exactly over the corner of the chine. Plane fore edge of plywood, if necessary. Pour hot water on these planking pieces to make them flexible enough to bend in place on the framework. Cover with water soaked rags on both sides to prevent drying.

While the fore planking pieces are soaking, cut four 4-in. wide strips of 3/8-in. plywood for butt blocks where fore and aft planking will join (Fig. 9 page 59). Cut these strips so that grain of the outer plies runs across the 4 in. width. Glue and clamp one of these strips to the fore end of each piece of planking already fastened to the hull. Fasten with #6 x 3/4-in. fh

butt tightly against the edge of the bottom planking (Fig. 15). Do the same with the other sheet of plywood for the other side of the framework. Glue coat all contacting surfaces and fasten planking in place with #8 x 1 1/4-in. fh screws spaced 3 in. apart along sheer and chine and 4 in. apart at the frame sides. The aft side planking pieces, which are 4 x 10 ft. sheets of 3/8-in. plywood, are then fitted, marked and cut to shape. Fasten with glue and screws as you did the planking. Install two 4 in. wide strips of 3/8-in. plywood for butt straps where the side planking pieces are joined.

After the glue dries, plane the edges of the side planking flush with the bottom planking and stem upright. Then fill in the gap between the bottom planking along the keel (Fig. 13),

with a tapering strip of 1/4 in. plywood.

To determine the taper at which to cut the outer stem piece (Fig. 5, page 57), hold a 5 ft. length of 2 x 8-in. stock against the stem upright and mark along the edge of the plywood on each side. Then saw on lines and at an angle to coincide with the angle of the planking at the bow. Plane the forward side of this outer stem so

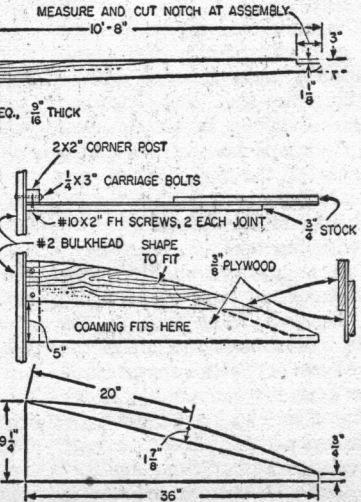
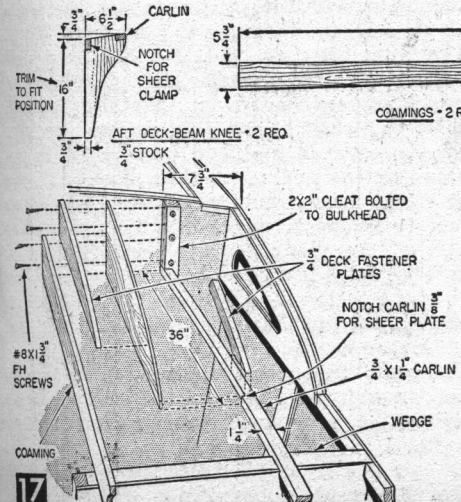

that the bow of the hull will be rounded rather than pointed. Fasten to the outer stem with glue and six #10 x 2½-in. *fh* screws, allowing it to extend beyond the bottom about 6 in.

Two pieces are required for the outer keel. Starting at the transom first fasten the 12-ft. length of ¾ x 1½-in. stock with glue and #8 x 1¾-in. *fh* screws spaced 6 in. apart. Then fill the gap between the outer stem and the 1½-in. wide outer keel with the 7-ft. length of ¾ x 3½-in. keel stock. Taper cut this piece from 1½-in. where it will join the aft outer keel to the width of the outer stem, also bevel the end so that it will fit between the outer stem and stem knee. Steam this section of outer keel and bend in place. Fasten with glue and #8 x 1¾-in. *fh* screws. Then fair the end of the outer stem projecting beyond the bottom of the hull to blend in with the outer keel.

If you are going to fiber glass the hull, now, before any paint is applied, is the time to do it. First fill all screw heads and cracks or voids at seams with *Famowood* and thoroughly sand the stem, keel and planking. See Materials List for amount of fiber glass and resinote required to cover bottom of hull up to the waterline. Complete instructions for applying are supplied with the fiber glass when ordered from Herter's, Waseca, Minnesota.

If you are not going to cover the hull bottom with fiber glass, apply two coats of *Firzite* to the entire hull exterior. Follow this with two thinned coats of *Kuhls Brushblast* and for a final finish, two coats of *Condon's Boatlife* enamel. A fiberglassed hull should also be painted using the same procedure and materials with the exception of the two coats of *Firzite*.

Turning the hull over, which is your next step, will require the help of 2 or 3 men besides yourself. Perhaps the simplest way to do this is to first jack up one side of the hull about 4 ft. and then gradually ease it over with a rope fastened around the hull and snubbed around a tree or stake driven in the ground. Fasten the rope to C-clamps on the #2 and 3 frames on the far side of the hull. When you have one side of the hull jacked up about 4 ft., 2 or 3 men can push it over the balancing point and gently lower it with the rope.

To keep the hull in an upright position once you have it turned over as in Fig. 16 build the storage cradle (Fig. 20). Then jack up the hull, slide the cradle underneath and lower the hull onto it. Use wedges between supports and hull where needed to keep it from rocking. Block up the keel in several places to keep it straight. Be sure to cover the open top of the hull with a tarpaulin when you are not working on it.

Building up the keel and bottom battens to

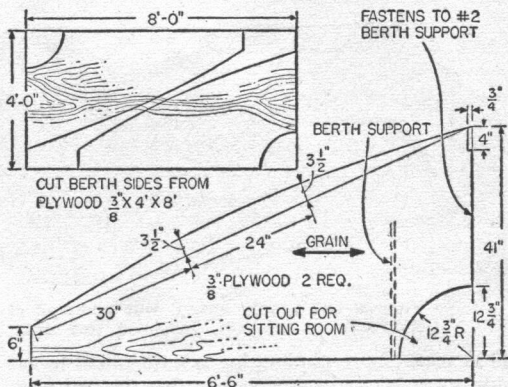
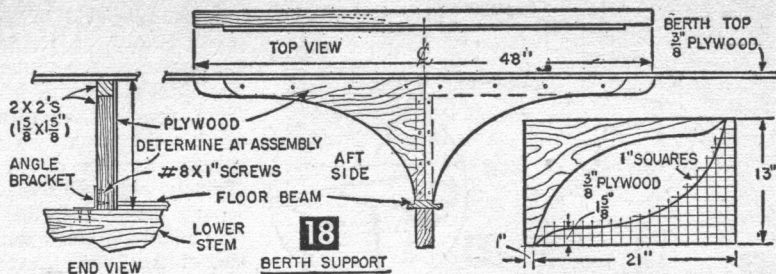

stiffen them is your next step. Starting with the floor beam (Sec. B-B Fig. 9, page 59), cut this member 12 ft. 2 in. long and rabbet the top long edges ¾ x ¼ in. Bevel the aft end 15° to fit against the transom and place it in the hull centered over the keel. Then mark and cut notches ¾ in. deep in #2, 3 and 4 frames for the floor beam.

The space between the keel and floor beam is filled with struts cut from 2 x 4 in. stock. Measure and fit these struts to fit snugly between the frames and drill a series of 1 in. holes through them spaced about 8 in. apart. Fasten the struts and floor beam in place with glue and ¾ x ¾ in. triangular fillets ripped on a circular saw. Fasten fillets with 1 in. galv. nails, and floor beam with #8 x 1¾ in. *fh* screws to frames and struts.

The bottom battens (Sec. C-C Fig. 9 on page 59) are built up in a similar fashion, only ¼ in. plywood is used for struts. Carefully measure and fit each strut between the frames. Be sure they are seated in the ¼ in. grooves cut in the bottom battens and make them flush with the tops of the lower frame members. Make short struts extending forward of #2 frame to the center of the planking butt block. Cut eight ¾ x ¾ in. strips 12 ft. long for longerons on each side of the batten struts. Notch the frames and transom and cut holes in the bulkheads for these longerons.

To install the longerons, you will have to feed them through the holes in the bulkheads by bending them over the transom. Fasten the batten struts to the grooves in the battens with glue and ¾ x ¾ in. triangular fillets nailed in place. Fasten the longerons to the struts and

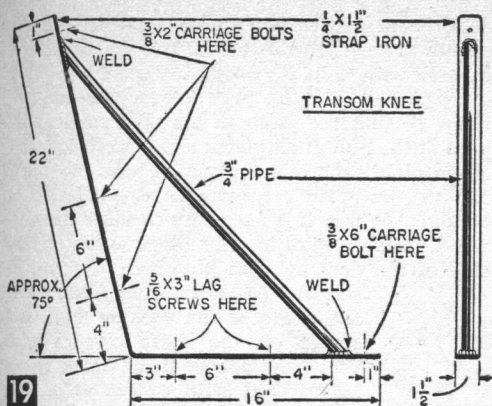

frames with glue and $1\frac{1}{4}$ in. nails.

When making the transom knee (Fig. 19) heat and bend the $\frac{1}{4} \times 1\frac{1}{2}$ in. strap iron and fit it in place on the keel against the transom so that you are sure the angle of the bend is correct. Then have the $\frac{3}{4}$ in. pipe welded in place and bolt the knee to the transom and keel. While you are working at the aft end of the hull, make up two aft deck-beam knees (Fig. 17), and one aft deck-beam (5A in Fig. 3, page 56). Notch the knees to clear the sheer clamps and fasten to the side planking 18 in. forward of the transom as in (Fig. 2, pp. 54-55). Use three #8 x $1\frac{1}{2}$ in. *fh* screws for each knee driven through the side planking from the outside. Then bolt the aft deck beam to the forward side of the knees with two $\frac{1}{4} \times 2$ in. carriage bolts at each end.

For the carlins, extending along the sheer from the transom to the #2 frame bulkhead (Fig. 9, page 59), rip two 12 ft. lengths of $\frac{3}{4} \times 1\frac{1}{4}$ in. stock. Notch the forward ends $\frac{3}{8} \times 36$ in. as in Fig. 17 for the $\frac{3}{8}$ plywood sheer plates. When assembling to the hull, notch the top transom frame piece $\frac{3}{4}$ in. deep, 6 in. from the side planking to take the carlins flatwise ($1\frac{1}{4}$ in. side horizontal). Also notch the aft deck beam and #3 and 4 frames as dimensioned in Fig. 9. The notch in the #3 frame should only be $\frac{1}{4}$ in. deep. Nail a wedge tapering from $\frac{1}{2}$ in. to nothing to the top of the bulkhead as in 19. Bolt a 2 x 2 in. cleat to the #2 frame bulkhead directly above the end of the carlin with two $\frac{1}{4} \times 3$ in. carriage bolts and nail the carlin to it. Fasten the carlin at each frame notch with one #8 x $1\frac{1}{2}$ in. *fh* screw.

When you have both carlins in place, make two $\frac{3}{8}$ in. plywood sheer plates (Fig. 17) and fasten them to the carlins and 2 x 2 in. cleats on the bulkhead with glue and #8 x 1 in. *fh* screws. Now, make up two coamings as in Fig. 17 and fit in place on the cockpit sides of the carlins. Place a piece of $\frac{3}{8}$ in. plywood over the aft deck beam to take the place of the decking when cutting the notch at the aft end of the coamings. Temporarily clamp the coamings in position and then fasten with a few locating screws.

With the coamings in place, make the two $\frac{3}{4}$ in. deck-fastener plates from scrap stock, by marking the curves directly from the sheer plate. Fasten with glue and $1\frac{1}{4}$ in. galv. nails. The coamings can then be removed and set aside until later.

Right now, before the fore decking is applied, is a good time to install the rope storage bulkhead and cabin berths shown in Figs. 2 and 9, pp. 54-55, 59. Make a cardboard pattern of the bulkhead taking dimensions directly from the hull. Then transfer the pattern outline to $\frac{3}{8}$ in. plywood and cut to shape. Drill 1 in. holes in bulkhead about 4 in. apart for ventilation and fasten to 1A deck beam and keel upright with #8 x 1 in. *fh* screws.

Berth supports on the #1 and 2 frames are already in place, so you need only make the one shown in Fig. 18. Place a straightedge di-

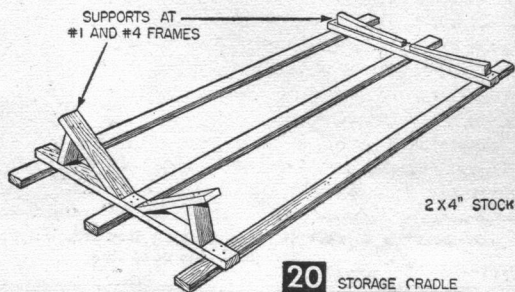

agonally across the supports on the #1 and 2 frames and measure the distance from the top of the lower stem to the bottom of the straightedge. It should be $12\frac{1}{2}$ in. If not, change the $12\frac{1}{2}$ in. height distance on the support in Fig. 18 to coincide. After making the support, fasten it to the top of the lower stem just forward of the floor beam with a $2\frac{1}{2}$ in. angle bracket.

When laying out the shape of the $\frac{3}{8}$ in. plywood berths (Fig. 18) it would be wise to first cut one out of cardboard (the type that doors and mattresses are shipped in) and fit it in the hull, making any cutouts and adjustments to clear frame ribs etc. Then transfer the outline to the plywood and cut to shape. Before fastening berths in place, paint inside of hull that will be covered by berths and underside of berths with two coats of primer followed by one coat of enamel. When dry, fasten berths in place with #8 x 1 in. *fh* screws.

With the forward cabin berths fastened in place, continue painting the inside of the cabin. Do not, however, paint the top surfaces of the deck plates and beams because the decking must be glued to these surfaces.

Start installation of the decking at fore end of hull by placing a 4x10 ft. sheet of $\frac{3}{8}$ in. plywood on the deck beams with a 10 ft. edge centered on the deck batten as in Fig. 2. The plywood will extend about 10 in. beyond the #2 bulkhead frame when the fore edge is flush with the curved

outer stem. Temporarily clamp the sheet down and mark the underside along the sheer, outside of bulkhead and carlin gusset. The 10 in. projection becomes part of the side planking at the curved sheer line. Remove the plywood and saw to shape. Then replace it on the hull and fasten with glue and #8x1¼ in. *fh* screws spaced 3 in. apart. Repeat the procedure on other side.

Now going to the aft end of the hull, install the three aft deck battens as in Fig. 23. Notch the battens into the top transom frame piece and aft

deck beam and fasten with two #8x1¼ in. *fh* screws at each joint. Aft deck and side decks are covered with ¾ in. plywood. Utilize left-over and scrap pieces of ¾ in. plywood for this and arrange so that the grain in top ply runs lengthwise of the hull at all places except at the curved sheer plate where the plywood must be bent. Having the grain crosswise here will facilitate bending. Where it is necessary to splice the plywood, fasten a ¾x3 in. butt block to the underside of the decking with glue and #8x1 in. *fh* screws. After the glue dries, plane the edges of the decking flush and round off the sharp corners with coarse sandpaper if the decks are to be covered with canvas as on the original Sea Hawk. The decks, however, could be stained and varnished if you prefer a natural wood finish.

Ten yards of 48 in. wide 6 oz. canvas or heavy-weight muslin will be required to cover the decks. Cut the canvas to fit over the decks allowing 1 in. overhang along the sheer and cockpit edges for tacking in place. Where canvas must be spliced, allow 1 in. overlap. To fasten the canvas to the decking, first apply a coat of Kuhls canvas cement as it comes in the can to the bare plywood decks. Use the stub of a worn paint brush

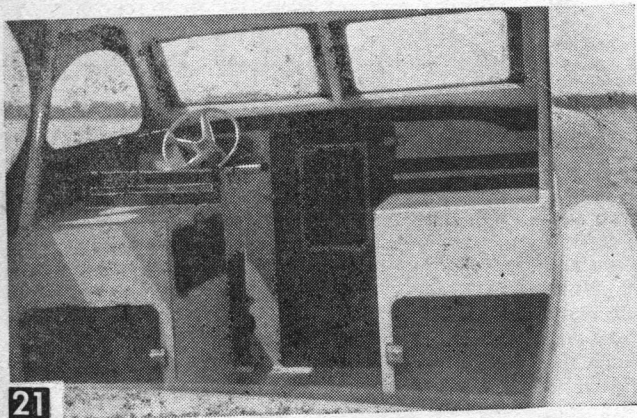

21

Interior view of cockpit cabin looking forward. Pilot's seat is on port (left) side of cabin.

1958 OUTBOARD MOTOR CALCULATED PERFORMANCE DATA TWO-CYCLE MOTORS (continued from p. 62)

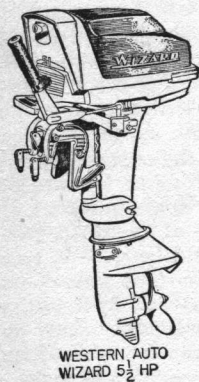

WESTERN AUTO
WIZARD 5½ HP

*Rpm at which Mercury motors develop advertised hp is not announced by company; hence, these figures, taken from collateral printed material, should not be viewed as conclusive.

	HP @ RPM	HP/RPM	NO. CYL.	BORE, INCHES	STROKE, INCHES	PISTON DISPLACEMENT, CU. IN.	HP CU. IN.	DISPLACEMENT CU. IN. PER MINUTE	PISTON TRAVEL FT. PER MIN.	WEIGHT LB.	LB. HP
Firestone.....	16@4200	.00381	2	2.3437	2.3125	19.95	.802	83,790	1940	68	4.25
Oliver.....	16@4500	.00355	2	2.5	2.0312	19.9	.802	89,730	1522	79	4.84
Scott-Atwater.....	16@4200	.00381	2	2.3437	2.3125	19.95	.802	83,790	1940	80	5
Wizard.....	15@4200	.00357	2	2.5	2.0312	19.9	.754	83,580	1420	75	5
Buccaneer.....	12@4000	.00300	2	2.25	2.25	17.89	.67	71,560	1500	77	6.4
Evinrude.....	10@4000	.00250	2	2.375	1.875	16.6	.60	66,400	1250	67	6.7
Firestone.....	10@4200	.00238	2	2.1719	2.0	14.82	.675	62,240	1400	59	5.9
Johnson.....	10@4000	.00250	2	2.375	1.875	16.6	.60	66,400	1250	67	6.7
Mercury MK-10.....	10@4250*	.00235*	2	2.3437	2.125	18.5	.54	78,625*	1500*	68	6.6
Scott-Atwater.....	10@4200	.00238	2	2.1719	2.0	14.82	.675	62,240	1400	65	6.5
Evinrude.....	7.5@4000	.00187	2	2.125	1.75	12.4	.604	49,600	1160	59	7.8
Johnson.....	7.5@4000	.00187	2	2.125	1.75	12.4	.604	49,600	1160	59	7.8
Scott-Atwater.....	7.5@4200	.00178	2	2.0	1.5	11.0	.68	46,200	1240	60	8
Mercury MK-6.....	6@4250*	.00141*	2	1.75	1.5	7.2	.83	30,600*	1064*	42	7
Oliver.....	6@4500	.00136	2	2.0	1.5	9.42	.627	42,390	1124	50	8.3
Evinrude.....	5.5@4000	.00137	2	1.9375	1.5	8.84	.622	35,360	1000	56	10
Johnson.....	5.5@4000	.00137	2	1.9375	1.5	8.84	.622	35,360	1000	56	10
Wizard.....	5.5@4200	.00131	2	2.0	1.5	9.42	.584	39,600	1050	55	10
Buccaneer.....	5@4000	.00125	2	1.9375	1.5	8.84	.565	35,360	1000	56	10
Firestone.....	5@4200	.00119	2	1.6875	1.6718	7.48	.668	31,416	1180	42	8.4
Scott-Atwater.....	5@4200	.00119	2	1.6875	1.6718	7.48	.668	31,416	1180	50	10
Firestone.....	3.6@4000	.00090	1	2.125	1.75	6.23	.578	24,920	1164	36	10
Buccaneer.....	3@4000	.00075	1	2.125	1.5	5.32	.564	21,280	1000	32	10.6
Evinrude.....	3@4000	.00075	2	1.5625	1.375	5.28	.565	21,120	912	33	11
Johnson.....	3@4000	.00075	2	1.5625	1.375	5.28	.565	21,120	912	33	11

or metal spreader—the type used for floor tile mastic. Then immediately spread the canvas over the cement, and using a piece of plywood as a spreader, rub the surface of the cloth to impregnate it with the cement. Work out all wrinkles and tack the folded-down edges with 1/4 in. copper tacks. Thin the remaining cement with turpentine or benzine to the consistency of thin paint and apply a coat to the canvas. Allow the decks to dry or cure at least two weeks before walking upon them. When cured, apply 3 coats of thinned paint of the desired color. After the paint has dried, permanently fasten the previously made coamings to each side of the cockpit.

Installation of the combination cockpit storage cabinets and seats is your next job. First lay out and cut two cabinet sides (Fig. 24A). Then,

using one of the side pieces as a pattern, lay out and cut two cabinet coaming sides (Fig. 24B). The pieces cut out for the door openings can be used to make the doors by facing them with a piece of 3/8 in. mahogany plywood 1/2 in. longer and wider than the cutouts as in Fig. 24C.

Next, fasten the 3/4 in. seat-back reinforcement pieces and other 3/4x1 1/8 in. and 1 1/8x1 1/8 in. pieces to the cabinet sides with glue and 1 1/4 in. galv. nails. Be sure to fasten the pieces on opposite sides on each one to make them pairs or right and left hand. Install the cabinet sides in the hull, fastening the vertical edge to the #3 frame bulkhead and the lower edge to the top rail of the bottom battens with glue and 1 1/4 in. galv. nails (Fig. 25). Fasten the smaller coaming side pieces to the #3 frame bulkhead with the 1 1/8x1 1/8

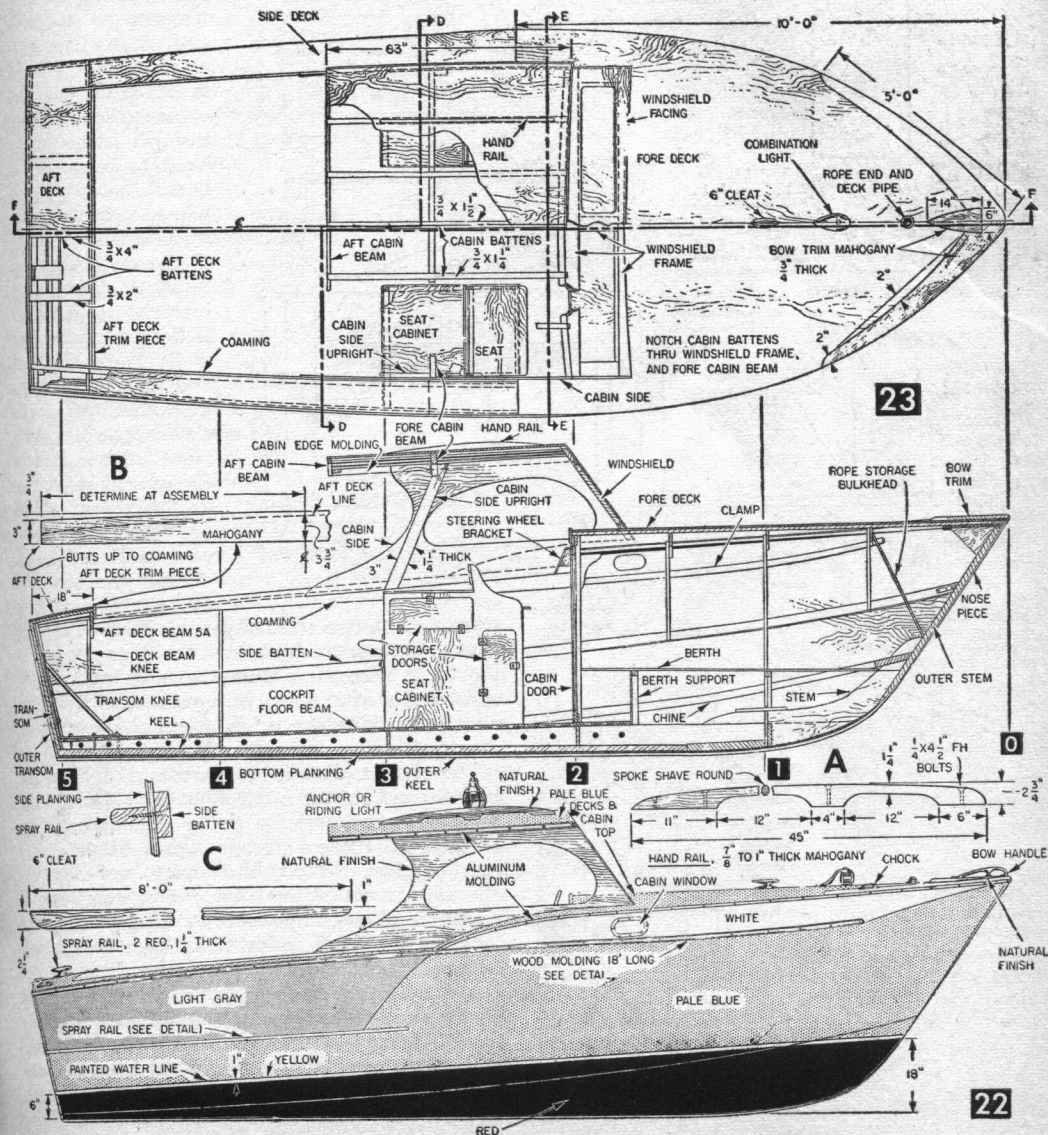

in. cleats. Allow a $\frac{3}{8}$ in. gap between these coaming side pieces and the coaming for the $\frac{3}{8}$ in. plywood cabin sides to be added later. To temporarily secure the forward end of these cabinet sides, place a scrap piece of $\frac{3}{8}$ in. plywood between the seat back projections and the coamings, and nail the cabinet sides to the coamings (Fig. 24E).

The cabinet fore bulkheads (Fig. 24D) are next. The best way of determining the exact size and shape to make these, is to mark out a cardboard pattern so that it exactly fits the fore end of the cabinet. Then use the pattern as a template to mark the $\frac{1}{4}$ in. plywood bulkheads. After cutting to shape, glue and nail the $\frac{3}{4}$ x $1\frac{1}{2}$ in. and $1\frac{5}{8}$ x $1\frac{1}{2}$ in. cleats to the bulkheads and as-

semble in position in the hull. Now, taking dimensions directly from the assembled cabinet sides in the hull, cut and fasten the cabinet top, shelf, seat and seat back pieces in place as shown in Fig. 24E.

To provide access to the lower part of the cabinets cut openings in the #3 frame bulkheads as shown in Fig. 4, page 56. Use kitchen cabinet hinges and latches on the doors. Cover the cabinet tops with a plastic kitchen-sink top covering material and use aluminum counter edging around the tops.

The cockpit flooring is made up of six pieces of $\frac{3}{8}$ in. plywood. Starting at the aft end of the cockpit, measure and lay out two large pieces of plywood to fit between the rabbet on the keel

floor beam to the chines and from the transom to the aft end of the storage cabinets. Nail $\frac{3}{4}$ x $\frac{3}{4}$ in. cleats along the chines (Fig. 25), and the #3 frame bulkhead to support the floor. The other four pieces of flooring are much smaller. Two of them extend from the forward ends of the pieces you just laid to the cabin bulkhead and between the keel and storage cabinets. The other two pieces cover the area in front of and below the cabinet seats. Install $\frac{3}{4}$ x $\frac{3}{4}$ in. cleats where needed to support the floor boards.

Paint the top and undersides of the

flooring with two coats of primer followed by one coat of deck enamel. So that the floor can be removed if necessary, fasten with #8 x $1\frac{1}{4}$ in. fh screws spaced about 6 in. apart. Also floor the area just inside the cabin door with two small pieces of plywood on each side of the keel.

The cockpit cabin is the next item of assembly. Lay out and cut the cabin sides (Fig. 27) to shape first. Then temporarily clamp them in position on the hull. Place a straightedge and level across the top edges of the cabin sides to make certain one side is not higher than the other. Since it would be almost impossible to hold the distance between the cabin sides to an exact dimension on every boat built, measure the distance between the cabin sides you have just clamped in position and make the windshield frame (Fig. 27) to suit your particular boat. Cut the top and bottom frame members from a single piece of lumber as in Fig. 27A by tilting the bandsaw table 35°. Fit the bottom member to the fore decking with a spoke shave.

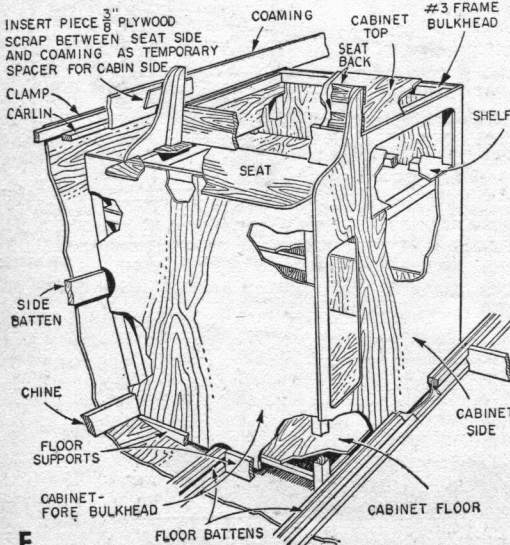
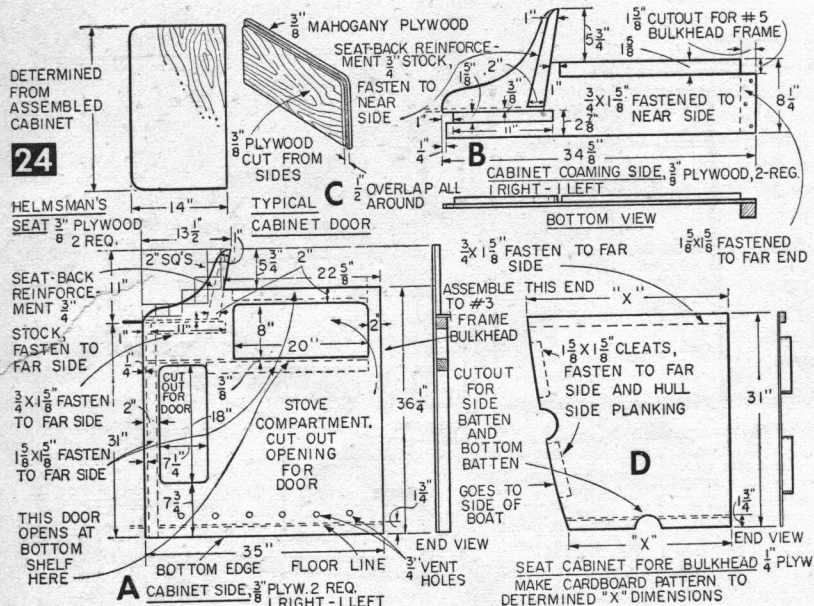

To determine the exact length to make the three vertical pieces of the windshield frame, temporarily fasten the top member in place between the cabin sides with a few nails. Then set the bottom member in place on the deck and measure the distance between them. Add 2 in. to the measured length for the tenons on each end of the vertical pieces. Assemble the frame with glue and clamp until dry.

Now, using the windshield frame as a template, lay out the windshield facing (Fig. 27). Be sure to allow $\frac{3}{8}$ in. at each end to overlay the cabin sides and $\frac{1}{2}$ in. along the bottom edge for the bevel cut. Then lay out the window openings and cut the facing pieces to shape. Make up the fore and aft cabin beams (Fig. 25), rip the cabin roof battens to size and fit the $1\frac{1}{4} \times 3$ in. uprights that reinforce the cabin sides. After notching the tops of these uprights for the fore cabin beam, fasten them permanently to the insides of the cabin sides with glue and #8x1 in. fh screws.

You are now ready to permanently fasten the cabin to the hull. Remove the cabin sides and coat the contacting surfaces along the coamings with *Bedlast*. Then reassemble with #8x1 in. fh screws. Install the windshield frame with *Bedlast* along the lower edge where it meets the deck and glue on the vertical edges contacting the cabin sides. Fasten to the deck with #8x1 $\frac{1}{4}$ in. fh screws driven from the underside of the deck and #8x1 in. fh screws through the cabin sides. Bolt the fore cabin beam to the $1\frac{1}{4} \times 3$ in. uprights with $\frac{1}{4} \times 5$ in. carriage bolts. Then notch the roof battens into the windshield frame and cabin beams, and fasten the aft cabin beam with corner braces and wood screws as in Fig. 25.

To finish the fore end of the cabin, fasten the windshield facing to the windshield frame with glue and #8x1 in. fh screws spaced about 6 in. apart. Apply *Bedlast* to the lower edge of the facing where it meets the deck before fastening it in place. Now make up two 65 in. lengths of cabin edge molding (Fig. 25A), cutting the $\frac{3}{4} \times 1$ in. rabbet for the plywood top at a 6° angle with a circular saw. Fasten to the cabin sides with glue and #8x1 in. fh screws from the inside of the cabin sides. Then install the $\frac{3}{8}$ in. plywood top with glue and 1 in. nails and cover with canvas as you did the fore deck. The $\frac{3}{4}$ in. aluminum molding covers the tacked-down edges of the canvas. Make two hand rails (Fig. 23A) and fasten to the cabin top directly over the outer roof battens with $\frac{1}{4} \times 4\frac{1}{2}$ in. fh galv. bolts.

Aluminum trim is also used to cover the tacked-down canvas edge along the fore deck sheer and

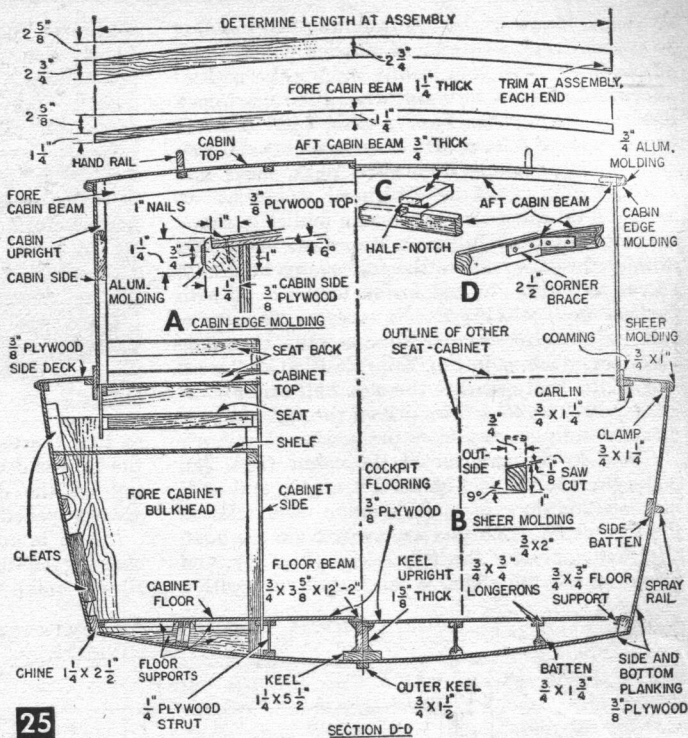

25

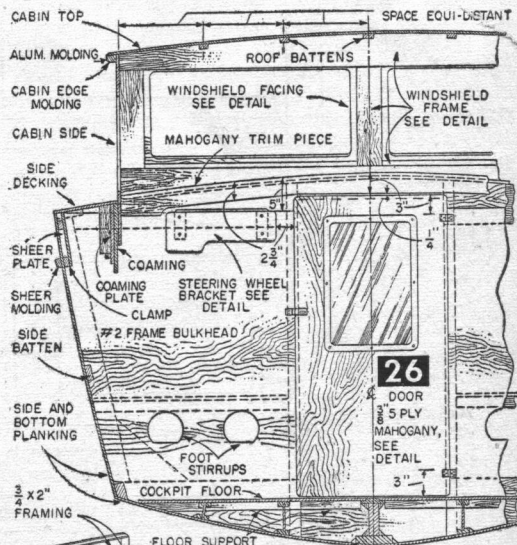

26

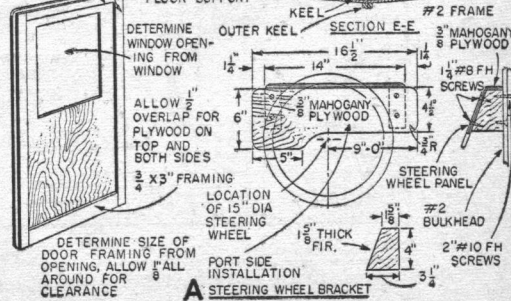

A STEERING WHEEL BRACKET

transom. However, before fastening this molding in place, rip two lengths of wooden sheer molding as in Fig. 25B, and install it along the cockpit sheer and straight forward below the raised-deck sheer as in Fig. 23. Fasten with #8x1¼ in. fh screws spaced 6 in. apart. Then install the aluminum molding along the raised deck sheer and transom with #6x1 in. oval-head monel screws spaced 6 in. apart. Use a wooden mallet to shape the aluminum molding at the sheer drop and around the bow. Make the mahogany bow trim pieces as in Fig. 23 and fasten to the deck with *Bedlast* and #8x1¼ in. fh screws. The spray rails, which also serve as bumper rails, are made of 1¼ in. stock as in Fig. 23C. Position at the aft end of the hull opposite the side battens. Fasten with #10x2 in. fh screws driven through the side battens and planking from the inside.

Going to the interior of the cabin (Fig. 21), make the door as in Fig. 26. Fit a hasp and padlock on this door for safe keeping of articles in the fore cabin when you are away from the boat. Use mahogany for the trim piece (Fig. 26), and round off the top edge. When installing, position

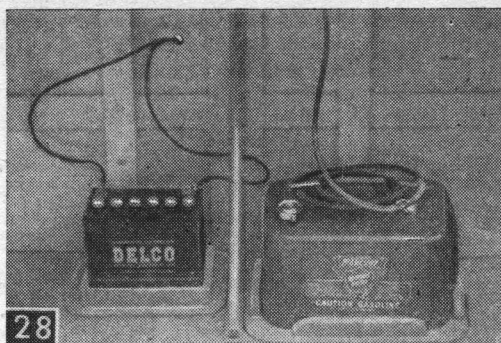

Battery and gas tank are located out of the way under the aft deck.

so that the top edge projects about ½ in. above the canvas deck to prevent small items from rolling off the deck. Fasten with #8x1¼ in. fh screws spaced 6 in. apart.

If you intend to use the *Mercury Ride-Guide* steering control as we did on the original *Sea Hawk*, make the steering wheel bracket as detailed in Fig. 26A,

and mount it on the left side of the cabin bulkhead. Mount the starter and throttle control on the coaming to the left of the pilot's seat and run all control cables under the left side deck back to the outboard motor.

The battery and gas tank are placed on the cockpit floor under the aft deck as in Fig. 28. Make the holders shown in Fig. 30, and fasten to the floor with #8x1¼ in. fh screws. The combination light on the forward deck and 360° white light on the cabin top are also connected to the storage battery. Hook up with the same type of wire used on automobiles and place the off-on switch on the cabin bulkhead in front of the pilot's seat.

Since the outboard motor can-

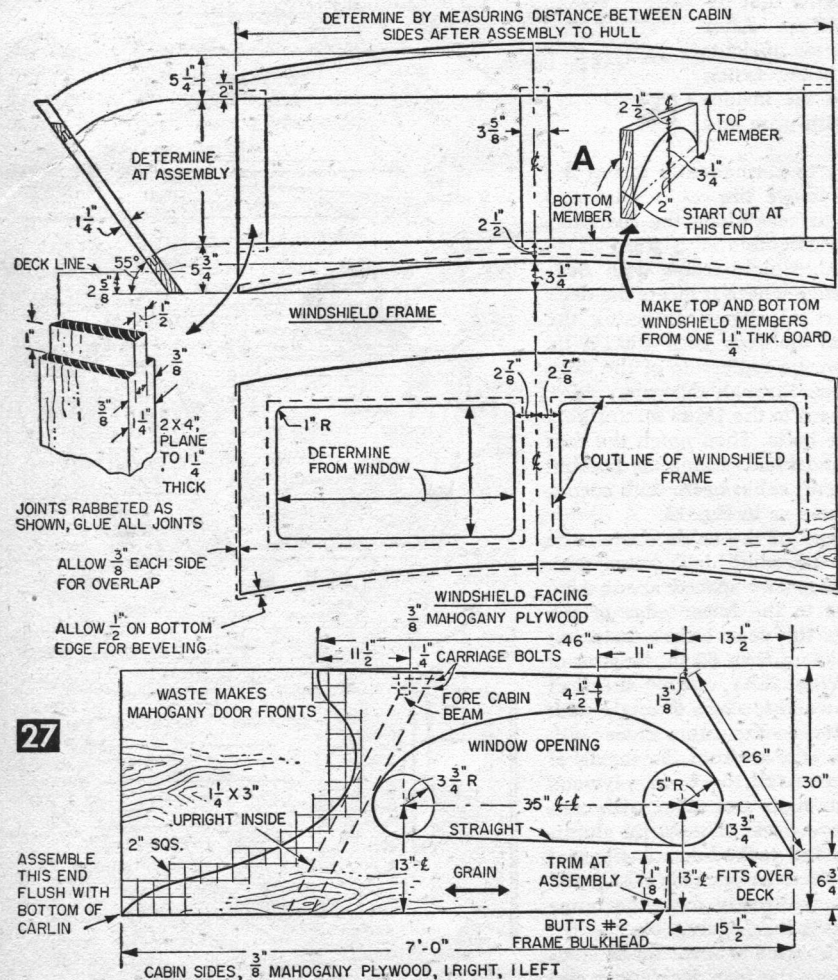

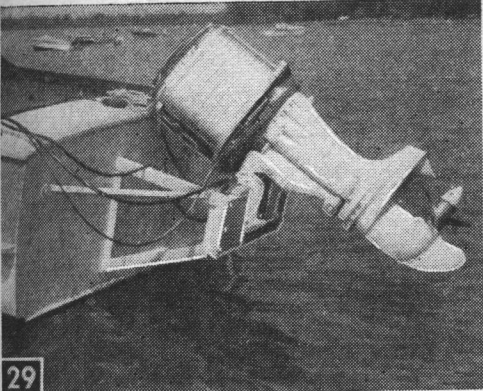

Strong, welded-steel bracket bolted to transom supports large 60 hp outboard motors.

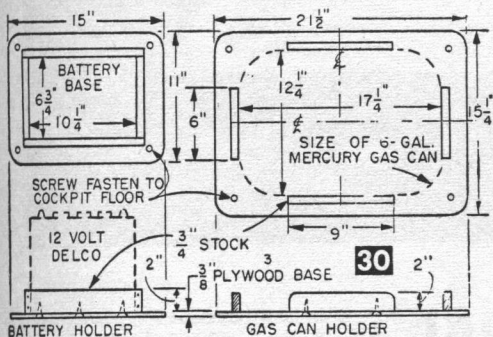

not be clamped to the transom, an outboard bracket (Fig. 29) must be used. Make one right and one left hand side for the bracket as detailed in Fig. 31. These must be arc welded—bolted construction will not stand up because of vibration. Glue the 1/4 and 3/4 in. plywood pieces for the motor board together using a dozen #8x1 3/4 in. fh screws instead of clamps to pull the pieces together. If you are going to use two 35 hp outboards instead of one 60 hp motor, make the board 44 in. wide.

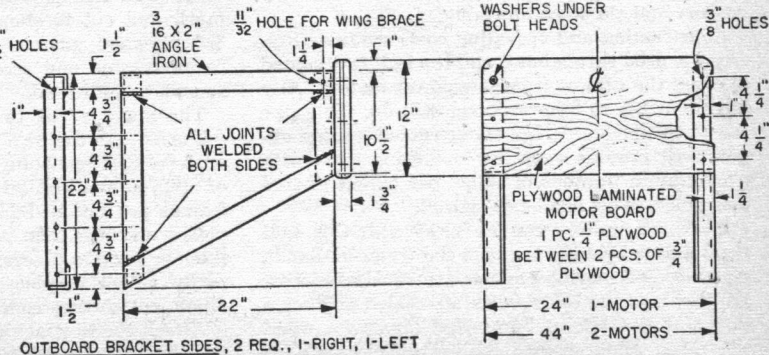
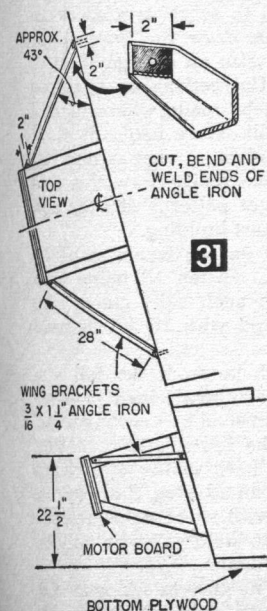

Bolt the motor board to the bracket sides as in Fig. 31. Then bolt the assembled bracket to the transom so that the mounting bolts go through the 2x4 in. reinforcing pieces on the inside of the transom. Make up the diagonal wing brackets and bolt them to the bracket and transom on each side as in the top view of Fig. 31. For the motor we used, a Mercury 1957 Mark 75 with long shaft, the top of the motor board measured 22 1/2 in. above the bottom planking. This distance is too high for use with standard or short-shaft outboards. Be sure to specify *long-shaft* when ordering your motor for this boat. Do not attempt to install an inboard engine in this boat because the bottom planking and structural members are not designed for it.

Right now, before any of the hardware or metal window frames are installed, complete the painting job. Start with the mahogany cabin sides, coaming, etc. that is to be given a natural-wood finish. Then if you splatter these surfaces while painting the other parts you can simply wipe it off with a rag. Open-grained wood such as mahogany must first be filled with a paste wood filler containing a mahogany stain. Use the filler on the end grain of the plywood also to darken it the same shade as the sides. The directions on the can will explain how to apply the filler and remove the excess. When dry, apply one coat of clear wood primer and follow with three coats of spar varnish, sanding lightly between coats.

For painted parts, apply two coats of primer followed with one coat of boat enamel of the desired color. The color scheme used on the original Sea Hawk is shown in Fig. 22. After the finishing coats are dry, seat the aluminum windshield windows in *Bedlast* and bolt them in place with zinc-plated bolts so they cannot be opened. Install the lights, cleats, chocks etc. as in Fig. 22.

● Craft Print No. 282 in enlarged size for building Sea Hawk is available at \$2. SPECIAL QUANTITY DISCOUNT! If you order two or more craft prints (this or any other print), you may deduct 25¢ from the regular price of each print. Hente, for two prints, deduct 50¢; three prints, deduct 75¢, etc. Order by print number. To avoid possible loss of coin or currency in the mails, we suggest you remit by check or money order (no C.O.D.'s or stamps) to Craft Print Dept. B58, SCIENCE AND MECHANICS, 450 East Ohio Street, Chicago 11, Illinois. See coupon on page 192. Now available, our new illustrated catalog of "186 Do It Yourself Plans," 10¢. Please allow three to four weeks for delivery.

